



CITY OF SAN FERNANDO OBJECTIVE DESIGN STANDARDS

FOR RESIDENTIAL &
MIXED-USE DEVELOPMENT

MARCH 2026 DRAFT

ACKNOWLEDGMENTS

CITY COUNCIL

Joel Fajardo	Mayor
Victoria Garcia	Vice Mayor
Mary Mendoza	Council Member
Mary Solorio	Council Member
Patty Lopez	Council Member

CITY STAFF

Kanika Kith	City Manager
Richard E. Padilla	City Attorney
Ron Garcia	Director of Community Development
Jose Mendivil	Planning Manager
Marina Khrustaleva	Associate Planner

PREPARED FOR:

City of San Fernando
117 Macneil Rd, San Fernando, CA 91340

PREPARED BY:

JZMK Partners
3080 Bristol Ave, Suite 350
Costa Mesa, CA 92626



ADOPTED BY:

Ordinance XX - X



This Project is funded and managed by the Southern California Association of Governments (SCAG) with Regional Early Action Program 2021 grant funding from the State of California Department of Housing and Community Development.

CONTENTS

1 INTRODUCTION

1.1	Purpose	8
1.2	Organization	9
1.3	Applicability	10
1.4	User Guide	13
1.5	Relationship With General Plan & Zoning Code	15
1.6	Terminology	16

2 SITE DESIGN

2.1	Edge Conditions	25
2.2	Publicly Accessible Common Open Space	27
2.3	Common & Private Open Space	30
2.4	Vehicular Access & Parking	34
2.5	Bicycle Circulation & Parking	39
2.6	Pedestrian Access & Circulation	41
2.7	Site Lighting	42

3 BUILDING DESIGN

3.1	Massing	49
3.2	Building Orientation	59
3.3	Neighborhood Transition	63
3.4	Façade Design	64
3.5	Ground Floor Uses	68
3.6	End Units	73
3.7	Window Alignment	73
3.8	Street Facing Transparency	74
3.9	Entry Typologies	76
3.10	Accessory Structures	87
3.11	Accessory Dwelling Units	89
3.12	Utilities, Service Areas & Building Equipment	90

4 ARCHITECTURAL STYLES

4.1	Overview And Applications	99
4.2	Spanish Colonial Revival	102
4.3	Ranch	110
4.4	Craftsman	116
4.5	Contemporary	122
4.6	Tudor Revival	128
4.7	Mission Revival	134

5 LANDSCAPE

5.1	Landscape Materials & Vegetation	143
5.2	Hardscape	150
5.3	Walls & Fencing	151
5.4	Landscape Lighting	162
5.5	Site Furnishings	166

INTRODUCTION

- 1.1 PURPOSE
- 1.2 ORGANIZATION
- 1.3 APPLICABILITY
- 1.4 USER GUIDE
- 1.5 RELATIONSHIP WITH GENERAL PLAN & ZONING CODE
- 1.6 TERMINOLOGY



1

1 INTRODUCTION

1.1 PURPOSE

1.1.1 OVERVIEW

The development of new residential and mixed-use projects in the City of San Fernando, which shall be referred to “City” in the following document, is regulated by a variety of documents including the General Plan, the Zoning Ordinance, and other topic-specific regulations. Following the passage of several state housing laws such as Senate Bill (SB) 35, SB 330, SB 6, and Assembly Bill (AB) 2011, designed to address the state’s housing crisis and streamline land use entitlements for housing projects, cities must now approve eligible housing proposals through ministerial processes that adhere to objective design standards. The City has chosen to adopt these objective design standards to streamline its housing development and review process, while also ensuring high quality design.

1.1.2 GOALS

The purpose of these Objective Design Standards is to require high-quality single-family, multifamily, and mixed-use residential development through a clear set of rules that are understandable to the general public, City staff, and the development community. The three primary goals of these standards are to:

- a. Preserve the character of San Fernando’s neighborhoods by balancing the form and design of existing development with new construction techniques and styles.
- b. Encourage human-scaled buildings that promote high quality site and building design.
- c. Emphasize a pedestrian-oriented environment where buildings and public realm design are cohesive and complementary of a diverse range of uses.

1.2 ORGANIZATION

The Objective Design Standards are organized, starting with an introduction, in six sections:

1. Introduction

2. Site Design

3. Building Design

4. Architectural Styles

5. Landscape

The Purpose subsection outlines the high-level goals of the section through subsections that organize one or more design standards to regulate specific design guidance. Additionally, the purpose of the ODS draws from Goals and Policies of the San Fernando General Plan. The design guidance is provided for each subsection with an intent statement that outlines General Plan and other planning policies and specific intent of the standards that follow.

1.3 APPLICABILITY

1.3.1 APPLICABLE PROJECT TYPES

These Objective Design Standards apply to all new residential and residential mixed-use development within the City of San Fernando in addition to:

1. Substantial renovations to existing structures, defined as the demolition or removal of 50% or more of exterior walls/roof.
2. Renovation to any existing residential or residential mixed-use primary structure that results in an addition of 50% or more to the existing square footage or 500 sq. ft., whichever is less.
3. Any exterior alteration that will add an upper floor/floors.
4. Accessory dwelling units.
5. These standards do not apply to minor renovations or routine maintenance.
6. These standards supplement the underlying base zone. In case of conflict between these standards, the ODS will apply.
7. All new developments covered by this section must conform to 1 of the architectural styles as described in Chapter 4 of the ODS.

Exceptions include the following:

1. All other project types including commercial-only projects.
2. Any interior renovation that does not modify the footprint or massing of an existing residential structure is not subject to the Objective Design Standards but must satisfy existing development standards set forth in the San Fernando Zoning Code and any applicable specific plan.

1.3.2 EXCEPTIONS & EXEMPTIONS

All applicable projects are required to comply with Objective Design Standards. Should a project not be able to or choose not to adhere to the Objective Design Standards, a project may seek approval through the following paths:

1. **Minor Exceptions and Exemptions.** If an applicant is unable to meet certain Objective Design Standards, applicant may request up to three (3) exceptions/exemptions. This allows for limited discretionary review and flexibility for projects that may have a physical constraint or alternative architectural solution to specific standards. The Community Development Director and/or designee will have full right to deny a project requesting these exceptions/exemptions.

Requests shall be made by the applicant in writing to the Community Development Director.

- a. Applicants requesting an exception/exemption shall provide findings on how their project meets the Purpose and Intent statement for each topic where the exception/exemption is requested.
 - b. Applicant shall document constraints to meeting the standard.
 - c. Exceptions/exemptions from quantitative standards shall not deviate more than 10% plus or minus from the standard.
2. **Discretionary Review Path.** Applicant may choose the Discretionary Review Path if they choose not to meet the Objective Design Standards. The Discretionary Review Path voluntarily takes a project outside of requirements including time of review and limit on number of public meetings for projects seeking non-discretionary approvals based on SB330. This process is outlined in the San Fernando Municipal Code Sec. 106-863.

1.3.3 DEVIATIONS

1. Up to twenty (20) percent deviations in Site Design standards may be approved by the Community Development Director, provided that if one standard is modified to accommodate a project, another standard from the same section of these objective design standards is modified by an equivalent amount. A total of two (2) deviations from Site Planning standards are permitted.
2. Up to ten (10) percent deviations in the Building Design standards may be approved by the Community Development Director, provided that if one standard is modified to accommodate a project, another standard from the same section of these objective design standards is modified by an equivalent amount. A total of two (2) deviations from Building Design standards are permitted.

Note: For projects that include affordable housing, these provisions apply in addition to any granted concessions or waivers.

1.3.4 DETERMINATIONS

In doing so, the Community Development Director and/or designee shall consider the following factors accordingly:

1. The interpretation aligns with the requirements outlined in the vision, intent, and purpose of the objective design standards.
2. The interpretation does not alter the intent of the objective design standards;
3. The decision constitutes a sound precedent for other similar situations; and
4. The resulting project is consistent with the General Plan.

1.4 USER GUIDE

The Objective Design Standards are intended for residents, property and business owners, developers, builders, architects, designers, and City staff involved in the review and approval of single-family, multi-family, and mixed-use developments within the City. The following steps are a quick way to understand the different sections of the document and how to use it.

Step 1: Review the Site Design Standards.

Site Design involves a careful analysis of the opportunities and constraints of the site, including but not limited to existing features such as mature trees, topography, drainage patterns, easements, and other dedications, such as public rights-of-way, open space, and stormwater buffers. The components of site development extend beyond building placement and configuration, including surrounding uses, retaining walls, landscape design, hardscape considerations, and parking.

Step 2: Review the Building Design Standards.

While new projects need not copy existing development, their mass and scale shall respect adjacent building context and uses. The Building Design standards establish requirements on these issues. These standards apply no matter which style is being utilized for the project design.

Step 3: Review the Architectural Style Standards.

The design and detailing of buildings are paramount to a quality environment, and the City is committed to authentic expressions of architectural style. Architectural design elements and materials shall be consistent throughout the project, recognizing that a building is 3-dimensional and must be well designed on all sides. Detailing, materials, window and door choices shall reinforce the overall project design. To provide guidance on architectural styles, the architectural standards offer a menu of elements and traditional details in which individual buildings may be designed.

The selected styles are based on prevailing designs in San Fernando's neighborhoods, specific plan areas and City planned development. Additional feedback has been provided from community outreach and an online survey to provide a range of appropriate styles.

The styles are as follows:

- **Craftsman**
- **Spanish Colonial Revival**
- **Mission Revival**
- **Tudor Revival**
- **Ranch**
- **Contemporary**

Within each style section, a description of various elements related to roof forms, windows, decorative details, and other topics are provided. The Architectural Style standards require certain elements, while other elements may be selected from a menu of options.

Step 4: Review the San Fernando Municipal Code and San Fernando Corridors Specific Plan (SP-5)

All developments must comply with the subdivision, land development, and zoning regulations contained in Chapters 78 and 106 of the San Fernando Municipal Code.

Step 5: Consult with the Community Development Planning Division

It is highly recommended for prospective applicants to obtain and become familiar with the application and submittal requirements for a project prior to a formal submittal. Additionally, the Community Development Department offers a Preliminary Site Plan Review service that is available to the public. This allows applications to receive staff review from various departments prior to a formal application submittal.

The San Fernando Municipal Code establishes required procedures for submitting and reviewing development applications. Applicants should consult with Community Development Department staff for assistance with these procedures and requirements.

1.5 RELATIONSHIP WITH GENERAL PLAN & ZONING CODE

The Objective Design Standards in this document work as a baseline, creating citywide standards that apply to all new single family, multi-family and mixed-use residential projects. This document shall work in tandem with the San Fernando Municipal Code or guideline documents, including but not limited to the City's General Plan and Zoning Code. Any design standards from the ODS shall supercede those in the General Plan or Zoning Code, if there are conflicting guidelines or regulations unless otherwise approved by the Director of Community Development.

- **General Plan.** The General Plan contains objective standards related to development density for all land uses in the City. The Objective Design Standards in this document are consistent with the General Plan and dictate the bulk, mass, and design of buildings in a more fine-grained way than the General Plan.
- **Zoning.** Chapter 106 (Zoning) of the San Fernando Municipal Code, and applicable Specific Plans contain objective standards such as setback, height, parking, and open space requirements. These district-by-district standards will continue to dictate basic development standards, and the ODS will apply in addition to these requirements, providing refinement in terms of site and building design. The ODS shall supercede any conflicting guidelines or regulations with the zoning code and specific plans unless otherwise approved by the Director of Community Development.
- **Other Municipal Code Sections.** The City also maintains and enforces standards including but not limited to stormwater drainage, roadway and traffic requirements, sewer, water and standards for working within the public right-of-way to install sidewalks, street trees, and lighting. These standards will continue to apply and will supercede any conflict with the ODS.
- **Building Standards Codes.** All construction in the State of California is subject to the California Building Standards Codes which dictate health, safety, and energy and water efficiency standards for new and remodeled structures. Refer to Chapter 18 (Buildings and Building Regulations) of the San Fernando Municipal Code for additional specifications and requirements. These standards will continue to apply and will supercede any conflict with the ODS.
- **Standard Plans & Specifications and Engineering Procedures Manual.** All public and private site improvements are designed and constructed in accordance with the Standard Plans and Specifications, as provided by the appropriate department, providing a framework for consistent, safe, efficient, and high-quality construction and maintenance of public and private infrastructure. These standards will continue to apply and will supercede any conflict with the ODS.

1.6 TERMINOLOGY

The following terminology is applicable to the Objective Design Standards and can be found within the ODS document. Definitions of terms found below apply only to this document and will take precedence over the San Fernando Municipal Code in cases of conflict, but only within the context of this document. Additional definitions that may be applicable to the ODS document may be found within the City of San Fernando Municipal Code.

Active Frontage: Active frontages are building frontages with active uses where there is visual engagement between those in the street and those on the ground floor. Active uses include retail stores, restaurants, markets, galleries, libraries, community centers, common areas and offices that generate high pedestrian traffic throughout the day.

Alley: A public thoroughfare used as a secondary vehicular means of access.

Back-of-walk: The edge of a sidewalk that is furthest away from an adjacent road, or closest to the extent of the right-of-way.

Block Length: The length of a parcel or series of parcels measuring from the edge of one public right-of-way or public access easement to another.

Building Envelope: The physical separator between the interior and exterior of a building, including the foundation, floors, walls, roof, windows, and doors.

Building Façade Length: The overall length of a façade without a full break in the building.(see full break definition below)

Building Façade Full Break: A significant interruption or separation in the façade, such as a passageway, courtyard, or a change in building height that visually and structurally divides the building.

Building Frontage Components Terminology: There are three zones that make up the space between a street’s curb to the building face. A fourth zone, the vehicle throughway, is where movement of autos and bikes occur.

1. **Frontage/Setback Zone:** Located on private property, provides a transition or buffer between buildings and the public realm and allows people to access buildings without interfering with pedestrian movement.

2. **Pedestrian Clear Zone:** Located in public right-of-way or a public access easement, this zone is where movement of people is the priority. Sidewalks or other hardscape surfaces meant for foot traffic are its defining component.

3. **Landscape/Furniture Zone:** Located in public right-of-way or a public access easement, this zone is where street trees, traffic control devices, and lighting are located; it provides a buffer between where people walk and the street.

4. **Vehicle Throughway:** Space intended for parking, drop-off or movement of mobile traffic, be it vehicular, personal electric transportation or bicycles.

Building frontage in public and private streets shall be designed in accordance with the zones illustrated below:

FRONTAGE/SETBACK ZONE	
<ul style="list-style-type: none"> Additional Dining Space Courtyards Building Arrival Space 	<ul style="list-style-type: none"> Planted Areas Hardscape Slope Areas
R.O.W. PUBLIC REALM	
PEDESTRIAN CLEAR ZONE	LANDSCAPE FURNITURE ZONE
<ul style="list-style-type: none"> Sidewalk 	<ul style="list-style-type: none"> Street Trees/Planting Street Lighting Seating Bike Parking Public Art Outdoor Dining Bus Shelters Utilities (e.g., hydrants)
VEHICLE THROUGHWAY	
<ul style="list-style-type: none"> Street Parking Bike Lanes Loading/Drop-Off Zones 	<ul style="list-style-type: none"> Parklets Bus Stops

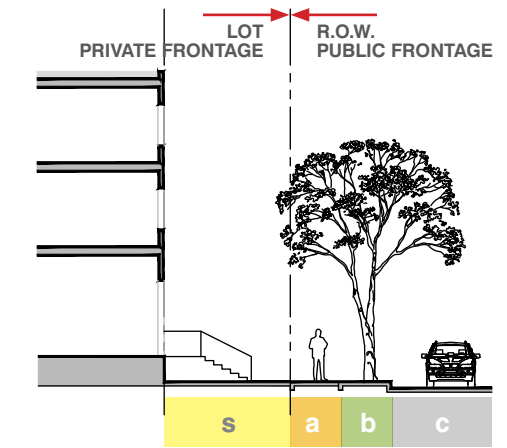

FIGURE 1.1 RESIDENTIAL FRONTAGE

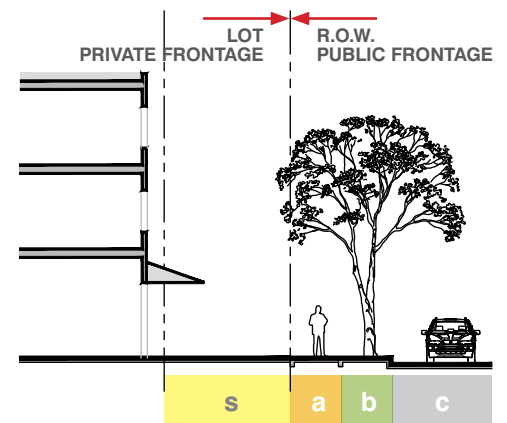

FIGURE 1.2 MIXED-USE FRONTAGE

- s Frontage/Setback Zone
- a Pedestrian Clear Zone
- b Landscape/Furniture Zone
- c Vehicle Throughway

TABLE 1.1: REQUIRED PUBLIC OPEN SPACE

Building Projection: The part or feature of a building which extends outside of the enclosing walls. It can be a building feature that is mounted on, and/or extends from the surface of the building wall or façade, typically above ground level.

Build-To-Zone: The area on the lot where all or a portion of the street-facing building facade must be located. It is established by a specific distance beyond the building setback from the property line.

Connection: A space that links one physical space to another. It may be traversable by pedestrian, bicycle or automobile traffic.

End Unit: A dwelling unit at the end of a connected row of homes with only one shared wall on one side. End units tend to include additional windows on the wall that isn't attached providing more natural light.

Façade Plane: Any stretch of a building façade existing along the same axis line, regardless of pattern differentiation or change in rhythm.

Façade Composition: The expression of a façade through a variety of techniques such as forms, patterns, fenestration, elements, details, materials, texture, finishes, etc. Façade Composition is used to create the architectural character and design theme of a building.

Façade Modulation: Used to shape a building's exterior massing, façade modulation is a change in building plane through the recess or projection of sections of a façade.

Foot-candle: A measurement of illumination on a one-square foot surface from a uniform source of light.

Footprint: Footprint or building footprint provides the outline of a building drawn along the exterior walls, with a description of the exact size, shape, and location of its foundation.

Height: The height of a structure is defined as the vertical distance from finished grade to the highest point of a structure.

Landscaped Area: Surface area dedicated for planting of trees, shrubs, flowers, ornamental grass, turf (natural or artificial), ground cover, or other horticultural elements.

Live/Work: A building or area within a building that combines both residential with commercial, retail or office use.

Modified Grid: An interconnected network of streets generally rectilinear in alignment and

orthogonal at intersections, with modifications to allow for terrain or environmental considerations, such as occasional curves or diagonally directed streets. The gridiron-like layout and shorter blocks typical of the modified grid street pattern allow for multiple travel routes, dispersing vehicular traffic within a geographic area, and encourage pedestrian activity.

Outdoor Rooms: Outdoor rooms are an extension of a living space, an outside space that promotes greater connection to the outdoor. It can include anything from an attached, screened-in porch to a detached gazebo or a landscaped area with a bench.

Public Park: All areas within the city, operated, maintained or controlled by the city that are designated for use as park, recreation or open space purposes, whether such property is a park, parkway, greenbelt, sports field, internal or adjacent sidewalks, general trail, on-street parking adjacent to park property, children's playground area, picnic area, or is maintained as open space, including undeveloped sites for future parks and includes any structure thereon.

Parking/Loading/Flex Zone: An essential zone for people and goods, providing separation between moving vehicles in the travel-way and people in the pedestrian realm. This zone can contain multiple uses along a street including commercial deliveries, parklets, on-street parking, and taxi, ride-share and micromobility zones. It can be used for mobility at specific times of the day.

Paseo / Pedestrian Path: A public place or path designed for walking; promenade that connects into or through a development.

Pedestrian-Scaled Block: A development block that is dimensionally sized to suit pedestrian flow rather than fit the needs of automobile traffic and circulation. Landscape and architectural elements are sized and spaced to be perceived from a short distance.

Perimeter Length: The lineal distance as measured along the perimeter of a building, parcel, lot, etc.

Planter: An above grade container for planting.

Podium: The lower floors of a building that form the "base" of a building typically including a courtyard level above. Podiums typically include structured parking, a courtyard level above, a different and larger floorplate than floors above, and may be a different construction type than the rest of the building.

Podium Level: The level directly above the Podium. The Podium Level typically includes a courtyard, a smaller building area than the levels below, and a change in construction type.

Primary Building Frontage: The building frontage that abuts the most primary of streets, or Pedestrian Pathway surrounding the building. In the case of a through-lot, the primary building frontage could be on either public right-of-way.

Primary Building Entry: The entrance to a building typically leading to a lobby, courtyard, or other large shared space that is accessed from the primary building frontage.

Primary Façade Plane: Majority area of the façade that is in the same plane.

Publicly Accessible Common Open Space: A Publicly Accessible Common Open Space area on a privately developed parcel that may include plazas, courtyards, seating areas, parks, parklets, play areas, recreational facilities or equipment, dog parks, etc.

Public Service Utilities Easement (PSUE): A portion of property that cannot be built on, planted on, otherwise covered or obstructed so that underground or overhead public utilities can be accessed for maintenance and repair.

Usable Green Space: An unobstructed area or areas, accessible in whole or in part to all occupants of the building it serves, and being available for safe and convenient use for recreation or leisure activities. It may be on roofs or structures or at grade and may include private balconies or patios but shall not include off-Street parking areas, off-Street loading areas or service driveways.

Step-back: A step-back (or building step-back) is an architectural design element that is typically applied to the upper-story of a building or development. Typically, a step back requires that any portion of a building above a certain height is further pushed-in towards the center of the property.

Storefront Commercial: Any commercial property located on the ground floor that has a storefront window that may be individually leased or rented for any purpose other than residential use.

Transparency: The amount of transparent area on a building façade.

Usable Open Space: The total combined open space areas of publicly accessible, common, and private open spaces.

Visible Light Transmittance: A measurement of the amount of light in the visible portion of the spectrum that passes through glass. The higher the number, the greater the amount of light that is passing through the glass. Visible transmittance (VT - expressed as a number from 0 to 1), is the typical measurement used for windows.

THIS PAGE LEFT INTENTIONALLY BLANK

SITE DESIGN

- 2.1 EDGE CONDITIONS
- 2.2 PUBLICLY ACCESSIBLE COMMON OPEN SPACE
- 2.3 COMMON & PRIVATE OPEN SPACE
- 2.4 VEHICULAR ACCESS & PARKING
- 2.5 BICYCLE CIRCULATION & PARKING
- 2.6 PEDESTRIAN ACCESS & CIRCULATION
- 2.7 SITE LIGHTING



2

2 SITE DESIGN

PURPOSE

- To set standards for building orientation, site access and utilities.
- To ensure quality design and site layouts that increase pedestrian comfort and safety.
- To define special conditions and set unique standards for these locations.
- To define location and uses for active frontages.

2.1 EDGE CONDITIONS

INTENT

- Support a “complete streets” approach to designing new streets and retrofitting existing streets by encouraging streets to provide stimulating settings; improve safe walkability, bicycling, and transit integration; strengthen connectivity; and enhance community identity through improvements to the public right-of-way such as sidewalks, street trees, parkways, curbs, human-scaled street lighting, and street furniture.
- Design sidewalks to create a safe, comfortable pedestrian experience by making sidewalks sufficiently wide to support circulation and outdoor activities related to adjacent land uses, planting a continuous tree canopy, and placing sidewalk furniture on regular, frequent intervals that do not impede travel or accessibility.

2.1.1 PUBLIC REALM

1. For projects fronting a public street right-of-way, the R.O.W. public realm (landscape/furniture zone + pedestrian clear zone) shall meet the following standards:
 - a. Single-family projects shall have a minimum public realm width of 12 ft. consisting of a 5 ft. wide unobstructed sidewalk/pedestrian clear zone and a 7 ft. wide landscape/furniture zone, ensuring that the space is fully usable, safe, and accessible.
 - b. Multi-family and mixed-use projects shall have a minimum public realm width of 12 ft., consisting of a 5 ft. wide unobstructed sidewalk/pedestrian clear zone and a 7 ft. wide landscape/furniture zone, ensuring that the space is fully usable, safe, and accessible.
 - c. Mixed-use projects with ground floor commercial. A minimum effective public realm width of 12 ft. with a minimum 5 ft. wide clear pedestrian zone and 7 ft. wide landscape/furniture zone.
 - d. Public Service Utilities Easement (PSUE). Where a PSUE exists on a property, the developer must adhere to established utility regulation. Developer to provide plan drawing to indicate PSUE is in coordination with the City to ensure compliance with the Objective Design Standards.

- For new developments, if the existing public sidewalk does not meet these minimum standards, a public access easement in the setback area shall be provided to extend the sidewalk width to the required minimum dimensions.

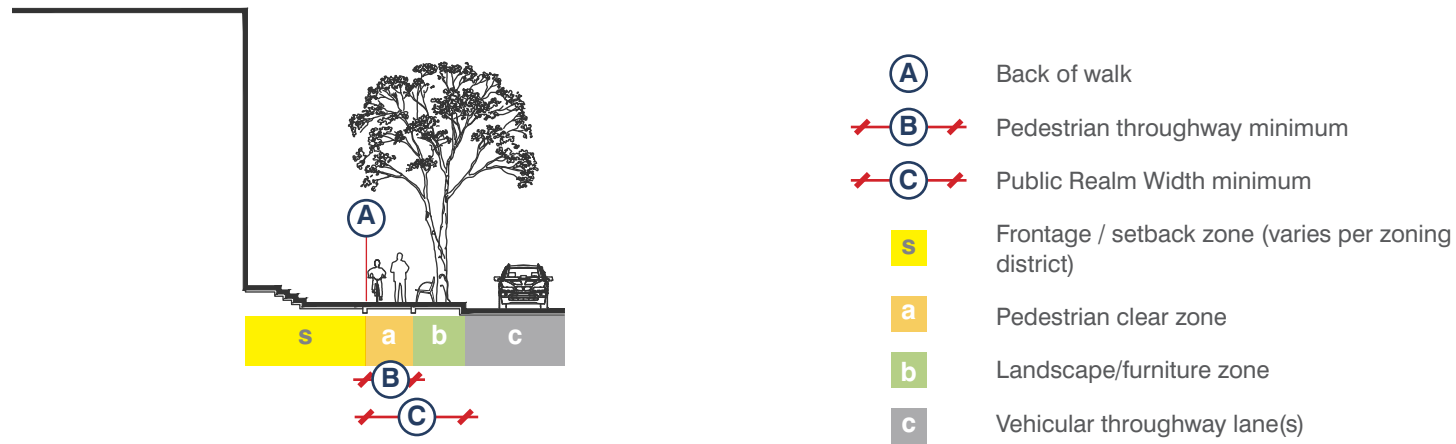

FIGURE 2.1: EFFECTIVE ROW PUBLIC REALM

2.2 PUBLICLY ACCESSIBLE COMMON OPEN SPACE

INTENT

- Promote vibrant Publicly Accessible Common Open Space that encourages gathering, social interaction and other active uses. Place a variety of supportive uses, such as amenities and services, adjacent to public spaces at sufficient concentrations to ensure safe and appropriate use of the spaces primarily during the day and early evening.
- Encourage the incorporation of Publicly Accessible Common Open Space, such as plazas, courtyards, seating areas, parklets, play areas, recreational facilities or equipment, dog parks, and usable green space, into new and existing multi-family, and mixed-use developments. The spaces should be appropriately scaled and programmed and compliment the characteristics of the district and/or neighborhood and the surrounding development.
- Configure buildings to provide “outdoor rooms”, including, but not limited to courtyards, paseos, and promenades.
- Maximize public exposure and views of park lands for scenic and security purposes.

2.2.1 APPLICABILITY

Publicly Accessible Open Space shall be required for all projects greater than or equal to two (2) acres in area. These requirements are in addition to minimum provided for in the Zoning Ordinance.

2.2.2 REQUIRED QUANTITY

The required Publicly Accessible Open Space quantity may include the City’s park dedication requirements. The minimum on-site requirement for any project that qualifies under this section shall be 5% of the total site area.

2.2.3 MINIMUM DESIGN STANDARDS

1. Publicly Accessible Common Open Spaces shall include one Contiguous Open Space that is equal to or greater than one-third (1/3) of the required Public Open Space area. This shall have a minimum dimension in any direction of 18 ft.
2. Publicly Accessible Common Open Spaces shall be located adjacent to a public right-of-way.
3. A public access easement shall be provided for the entire Public Open Space.

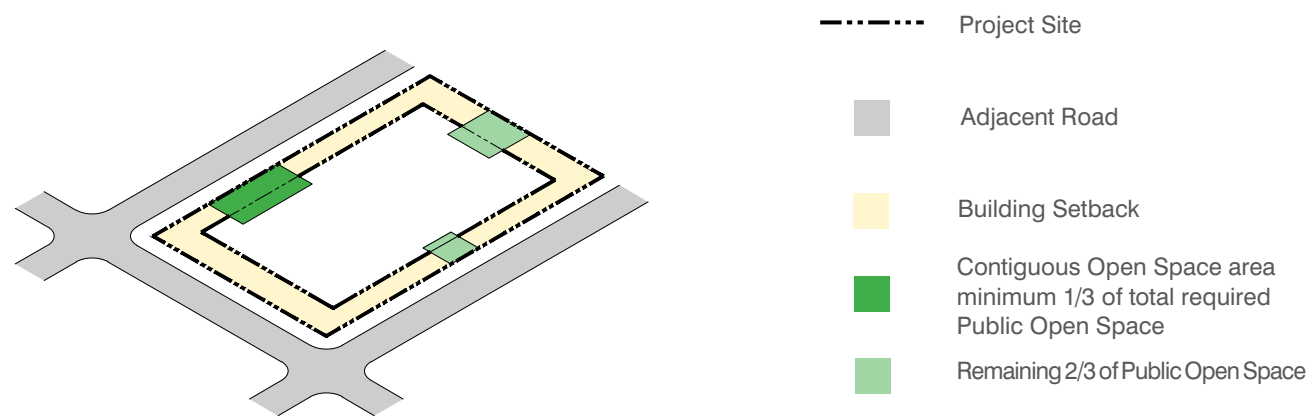

FIGURE 2.2: MINIMUM REQUIRED OPEN SPACE

2.2.4 ADDITIONAL PUBLIC OPEN SPACE STANDARDS

Off-street parking and loading areas, driveways, service areas, utility equipment, air conditioner pads, and storage structures shall not be counted as Publicly Accessible Common Open Space.

The following standards shall be met for all Publicly Accessible Common Open Spaces:

1. A public access easement shall be provided for the entire Publicly Accessible Common Open Space.
2. Shall be publicly accessible from dawn to dusk for a minimum twelve (12) consecutive hours per day during summer from 7 am - 7 pm and shall be open for a minimum nine (9) consecutive hours from 7 am - 5 pm during winter.
3. Shall be accessible from a public right-of-way or a publicly accessible lobby, with clear signage visible from the public right-of-way indicating the type of open space, hours of access, and amenities.

4. Fences and gates surrounding publicly accessible open spaces shall allow for unobstructed entry during open hours, maintain high visibility, and promote safety. These fences are exempt from standard zoning height restrictions and shall be a uniform 6 ft. in height to deter unauthorized access and climbing. To further ensure security, gates and fences must not include horizontal bars or footholds that could assist climbing.
5. Property owners have the authority to establish rules of conduct to ensure appropriate use and safety of the open space. They retain the right to remove individuals who violate these rules or engage in inappropriate behavior, in compliance with public open space regulations.
6. Shall have permanent seating (e.g., seat walls, planter ledges, benches, picnic tables, and seating steps) at a minimum rate of one bench or equivalent seating per 1,000 sq. ft. of area, ensuring sufficient seating throughout the space.
7. A minimum of 60% of the area shall be open to the sky and free of permanent weather protection or enclosed structures. Trellises and similar open-air features are permitted, provided that they have overhead louvers with opacity of no more than 50% across the surface of the trellis, ensuring that they do not significantly block natural light.
8. A minimum of 30% of the Publicly Accessible Common Open Space shall be landscaped. Landscaping shall primarily consist of trees and other plantings that do not obstruct visibility, avoiding dense shrubs or vegetation where people or animals could hide.
9. A minimum of 20% of the open space area shall be planted with ground cover and/or shrubs.
10. A minimum of one tree shall be planted per 1,000 sq. ft. of the open space area.
11. Hardscape surfaces shall not exceed a gradient of 1:12.
12. Open space on a roof or deck shall include safety railings or other protective devices that meet but do not exceed the minimum height required by the State Building Code.

2.3 COMMON & PRIVATE OPEN SPACE

INTENT

- Create well designed common and private open spaces that serve multiple purposes, encourage gathering, improve the health and wellness of residents and embrace nature in the built environment.

2.3.1 COMMON OPEN SPACE

This section applies to common open space that is private to multi-family residential projects and residential mixed-use projects. Common open spaces are outdoor open spaces that are available and accessible only to building residents and their visitors. Common open spaces may include courtyards, gardens, play areas, outdoor dining areas, recreational amenities, and rooftop open spaces.

1. Publicly Accessible Common Open Space may be counted toward the required Common Open Space, provided that it is designed according to Publicly Accessible Open Space requirements.
2. Common Open Space shall meet the following standards:
 - a. Shall not be located within 15 ft. next to arterial streets, service areas, or adjacent commercial development to ensure they are sheltered from the noise and traffic of adjacent streets or other incompatible uses.
 - b. Shall be designed to enhance the overall layout of the development and directly accessible from shared areas such as lobbies or hallways. When located adjacent to residential units, a minimum 6 ft. buffer for landscaping is required to ensure that the privacy and comfort of residents are preserved.
 - c. Shall be accessible to all residents of the development, including residential tenants, and, in the case of mixed-use developments, any commercial tenants as well.
 - d. For buildings four (4) stories and above, courtyards located between two parallel buildings or enclosed by three sides of a building, shall have a minimum width of at least 80% of the height of the tallest adjacent building façade, but not less than 25 ft..

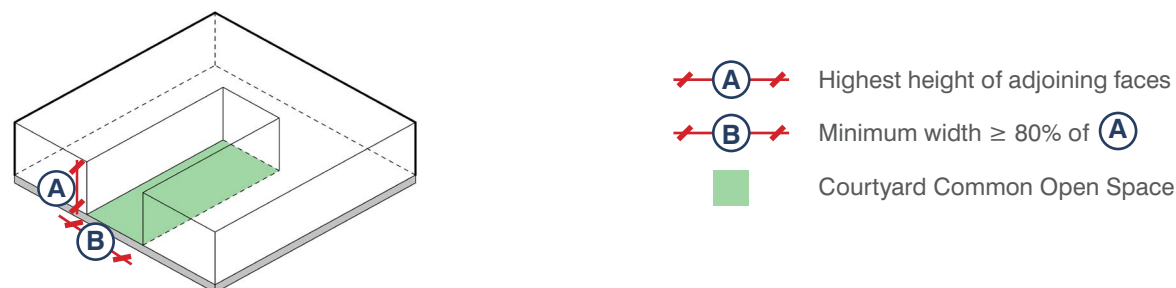

FIGURE 2.3: COMMON OPEN SPACE ENCLOSED BY THREE SIDES

- e. For buildings four (4) stories and above, courtyards fully surrounded by building walls shall have one dimension that is at least equal to or greater than the tallest height of any adjacent building (up to a maximum of 80 ft.). The second dimension must be at least 80% of that height. Adjacent building façade height is measured from ground level to the top of the wall, regardless of any upper-floor setbacks.

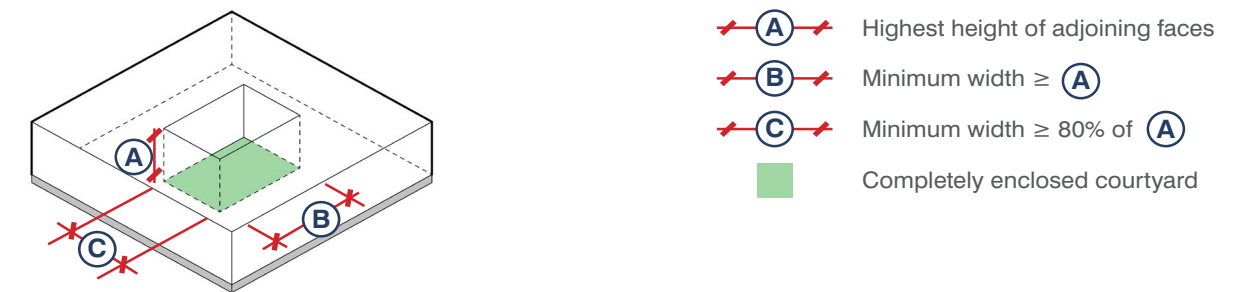



























FIGURE 2.4: COMMON OPEN SPACE DIAGRAM

- f. A minimum of 60% of the area must be open to the sky and free of permanent structures or obstructions. Trellises and similar open-air features are permitted but must not exceed 50% opacity and should not cover more than 40% of the total open space area.
- g. A minimum of 25% of the common open space area shall be planted with trees, ground cover, and/or shrubs.
- h. All Common Open Spaces shall include a minimum of one seat for every 200 sq. ft. of common open space, such as benches, chairs, or seat walls. Site furniture shall be constructed with durable, graffiti-resistant materials and incorporate skateboard deterrents to maintain attractiveness and prevent damage.
- i. No more than 50% of the total area counted as Common Open Space may be provided on a roof.
- j. Buildings and roofed structures with recreational functions (e.g., pool houses, recreation centers, gazebos) may occupy up to 20% of the area counted as common open space.
- k. All recreational areas or facilities required by this section shall be maintained by the property owners.
- l. Common Open Spaces shall be constructed concurrently with the development. If the development is phased, the developer shall submit a phasing plan for review and approval by the city, detailing the timing and proportional completion of open spaces for each phase.

- All new developments shall include on-site recreational facilities in the amounts specified in Table 2.1. Depending on development size (units), the symbols below represent: (a) the minimum required amenities, and (b) the selection of amenities to choose from. Developments under ten (10) units are exempt from this requirement.

COMMON OPEN SPACE AMENITY TABLE

	DEVELOPMENT SIZE (UNITS)			
	10-49	50 - 79	80-200	201+
 MINIMUM 1				
 MINIMUM 3				
 MINIMUM 3				
 MINIMUM 1				
BARBECUE FACILITY EQUIPPED WITH GRILL, PICNIC BENCHES, ETC (MIN. OF TWO (2) AREAS)				
PLAYGROUND WITH MULTIPLE PLAY EQUIPMENT¹				
INDOOR GYM/FITNESS FACILITY (MINIMUM 500 SQ.FT.)				
SPA AND POOL AREA <small>SPA: MIN. 25 SQ. FT., MIN. DIMENSION OF 5 FT. / POOL: MIN. 1000 SQ. FT., MIN. DIMENSION OF 25 FT.</small>				
LARGE OPEN LAWN AREA, MIN. DIMENSIONS SHALL BE 100 FT. x 50 FT.				
MULTIPLE PLAYGROUNDS WITH PLAY EQUIPMENT¹				
LAP POOL (MIN. 60 FT. X 25 FT.) AND SPA (MIN. 25 SQ. FT., MIN. DIMENSION OF 5 FT.)				
COMMUNITY MULTI-PURPOSE ROOM EQUIPPED WITH KITCHEN, DEFINED AREAS FOR GAMES, EXERCISES, ETC. (MIN. 500 SQ. FT.)				
BARBECUE FACILITIES EQUIPPED WITH MULTIPLE GRILLS, PICNIC BENCHES AND SHADE STRUCTURES² (MIN. 12 FT x 15 FT)				
COURT FACILITIES (E.G. TENNIS, VOLLEYBALL, BASKETBALL, ETC.) (MIN. 96 FT x 50 FT)				

¹ Playgrounds shall be sized to accommodate adequate equipment to meet all Consumer Products Safety Commission guidelines and ADA Standards. All equipment must be submitted to the city for review. One large playground is preferred over smaller, less equipped functioning play areas. Minimum size for playground(s) is 75 sq. ft. per school-aged child using the playground at one time. (per NAHB tabulations of 2022 American Community Survey microdata, updated 11/2023, the average number of school-aged children is approx. 20.8 per 100 apartment households.)

²May be considered subject to the City's review and approval process.

TABLE 2.1 COMMON OPEN SPACE AMENITY STANDARD

2.3.2 PRIVATE OPEN SPACE

Private open space areas are intended for private use for each dwelling unit and may include balconies (covered or uncovered), patios, private gardens, private yards, terraces, decks and porches, among others.

- Private Open Spaces shall meet the following standards:
 - Ground-level Private Open Space shall be screened from adjacent Private or Common Open Spaces and dwellings using a stucco-covered masonry wall or wooden fence, with a height of up to 6 ft.
 - Above ground-level space shall have at least one exterior side open and unobstructed for at least 8 ft. above floor level, except for incidental railings, balustrades, and balcony walls.
 - Ground-level Private Open Space that faces abutting lots, streets, alleys, private driveways, or other areas on the same lot shall be screened by a building wall or one or a combination of the following methods with a maximum height of 6 ft.: landscaping, a solid masonry wall, or a grille fence.
 - Private open space(s) attached to residential units shall be designed to avoid direct visibility into the interiors of adjacent units.

2.3.3 GENERAL OPEN SPACE REGULATIONS

The following regulations apply to all required open space areas:

- All required open space shall be usable. Usable open space shall be improved to support residents' passive or active use. Such open space shall be located on the same parcel as the dwelling units for which it is required. The computation of such open space shall include no obstructions other than devices and structures designed to enhance its usability, such as swimming pools, changing facilities, fountains, planters, benches, and landscaping.
- Open space areas shall have no parking, driveway or right-of-way encroachments.
- Open space does not need to be located on the ground. Rooftop gardens and rooftop landscaping, including rooftops above parking structures, may be used to satisfy the open space requirement. Rooftop open space features and vertical projections such as sunshade and windscreen devices, open trellises, and landscaping shall not exceed 16 ft. in height beyond the maximum permitted height. Planter boxes exceeding three (3) ft. in height shall not count towards the open space calculation.

2.4 VEHICULAR ACCESS & PARKING

Refer to Chapter 106, Article 3, Division 3, Subdivision II of the San Fernando Municipal Code for off-street parking regulations.

INTENT

- Locate vehicular entries, parking areas, storage bays, and service areas of buildings to minimize conflicts with adjacent properties, especially residential neighborhoods. Also, parking, storage and service areas shall be sited to minimize their visibility from public rights-of-way.
- To minimize the visual impact of parking, loading and service areas, support pedestrian interest along public rights-of-way and other pedestrian ways, and minimize conflicts between pedestrians and vehicles along key streets.

2.4.1 VEHICULAR ACCESS HIERARCHY

1. Parking and service area access shall be provided in the following order, based on site characteristics:
 - a. From an alley.
 - b. In the absence of an existing or proposed alley, access shall be from a driveway shared with a property abutting the development site.
 - c. In the absence of an alley or shared driveway, access shall be from the side/lesser street abutting the development site.
 - d. In the absence of a side street, from a curb cut/driveway along the primary street frontage.

2.4.2 DRIVEWAYS AND CURB CUTS

These standards shall apply to driveways and associated curb cuts providing vehicular access to parcels improved with mixed-use and/or multi-family residential development projects. Alley frontages are exempt from these standards. Exceptions to these requirements may be granted upon review and approval by the City's traffic engineer if it is determined that the proposed location would not compromise traffic safety.

1. Each development project site shall be limited to one curb cut, including driveways and private/service streets, per 250 ft. of public street frontage, or two curb cuts per street frontage, whichever is less (unless otherwise required for emergency vehicle access).
2. Driveways shall be a minimum of 3 ft. from a property line or include a shared driveway access with adjoining parcel.

2.4.3 LIMITATION ON PARKING AND LOADING FRONTAGE

1. Off-street parking, off-street vehicle loading, and vehicular circulation areas (other than direct driveway access perpendicular to the street) shall be located on the interior side or rear of the site, and are prohibited between the building and primary street frontage.
2. No more than 30% of the primary street frontage shall be devoted to garage openings, carports, surface parking, or service/loading entries. For narrow lots where this limitation is not feasible, an exception shall be granted based on site-specific design review. This limitation does not apply to frontages along alleys.
3. Entries to structure parking when combined with loading, and utility/service areas shall at minimum be 30 ft. in width to allow service vehicle maneuverability. All other vehicular entries shall at minimum be 25 ft. in width.
4. Service entrances shall not face Maclay Avenue or San Fernando Road. All service entrances and associated loading docks and storage areas shall be located to the side or rear of the building.
5. Portions of the building facade containing service or truck doors shall be integrated into the architectural composition of the larger building facade design. Architectural treatments, materials, and colors shall be extended from building facade areas into the facade portion containing truck doors.
6. Roll-up security doors shall be detailed to conceal door housings and tracks, and provide an attractive and finished appearance for all exposed components.

2.4.4 RESIDENTIAL GARAGES

1. Garage doors shall be oriented away from the street to minimize their visibility from the public realm. Where this is not possible due to: (a) the lot not having enough width to accommodate a driveway to provide side or rear access garages, and (b) there is no alley to provide an alternative garage access, below are the following regulations:
 - a. The garage shall be set back a minimum of 19 ft. from the property line.
 - b. The garage door shall be located a minimum 4 ft. behind the primary façade. Exception: The setback requirement is modified if the garage door is adjacent to a porch that is at least 8 ft. long and 6 ft. deep; in this case, the garage door can protrude from the adjacent porch façade at a minimum distance of 18 inches with a maximum distance of 2 ft.

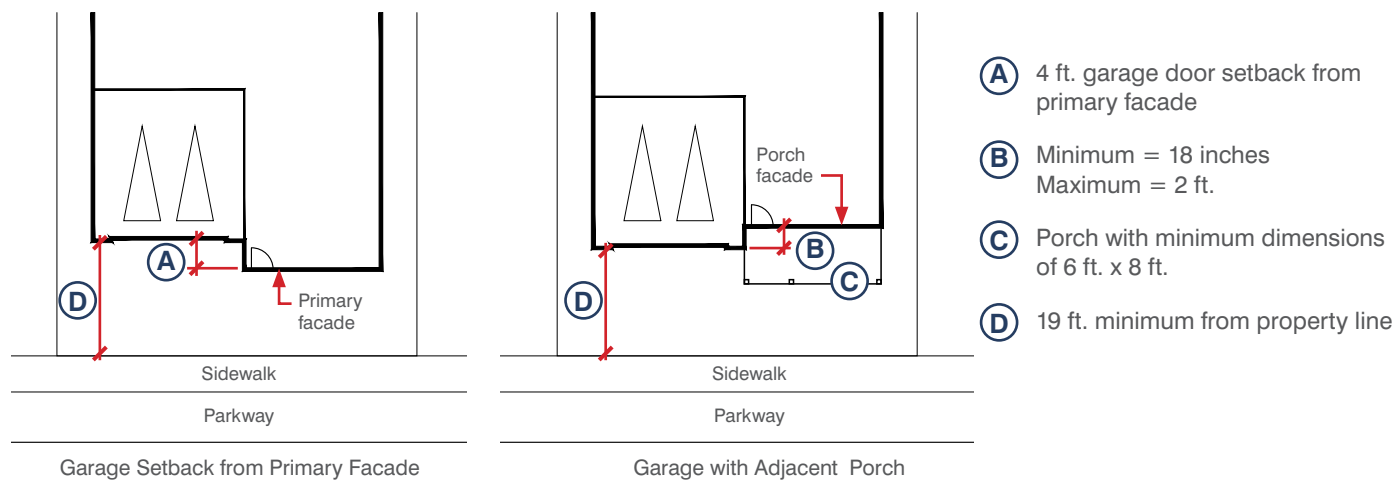

FIGURE 2.5: STREET-FACING GARAGE

2. The design of the garage door shall match the particular architectural style selected. Garage doors shall be set into the walls a minimum of 6 inches.
3. To avoid a car-dominated appearance on the facade, when double car width garage doors are used, doors shall not exceed a width of 20 ft. maximum.

2.4.5 STRUCTURED PARKING

1. Above-grade structured parking levels or podiums shall not be exposed to face Maclay Avenue, San Fernando Road, Truman Street, other primary streets, or any public open space. On these frontages the structure shall be lined with commercial or habitable uses. Commercial uses must have a minimum depth of 20 ft., and residential units must have a minimum depth of 16 ft.. Vehicular alleys are excluded.
2. Parking garages and podiums shall be treated with wall textures, colors, and dimensional modules that are coordinated with the primary structure.
3. No building shall have more than one garage or podium entrance per streetfront.
4. The pedestrian entrance to a parking structure or podium shall be designed as an easily noticeable change within the facade treatment.
5. Vehicular entrances shall not be located along Maclay Avenue, San Fernando Road, Truman Street, First Street, Second Street, or other primary streets unless it is the sole access point available to the site. Entrances shall be located along the side or rear of the building.
6. Vehicle entrances shall be treated with architectural articulation and landscape materials to “mark” a frequently used common entrance for residents and guests. Treatments shall include architectural frames or pergolas consistent with the architectural style of the building, decorative doorframe ornament, ornamental lighting, etc.
7. Exposed podiums shall not have blank concrete walls. Podium wall textures, colors, and dimensional modules shall be coordinated with those of the residential architecture above the podium. Detailing and design, such as decorative scoring, concrete blocks with special surface textures (split-face block, combinations with precision face, etc.) integral color and/or inset tiles are recommended to provide additional surface articulation.
8. All portions of partially subgrade parking visible above grade:
 - a. Shall not have an exposed façade that exceeds 5 ft. in height above abutting grade at back of sidewalk
 - b. Shall be architecturally treated no differently than that primary structure and;
 - c. Shall utilize the same level of detail, articulation, and materials as the primary façade, and;
 - d. Shall be screened with landscape screening (e.g., shrubs) a minimum of 3 ft. in height and/or crafted ornamental metal screens.

2.4.6 INTERNAL ACCESS

2.4.6.1 MULTI-FAMILY COMPLEX INTERNAL CIRCULATION

In residential rental apartment and condominium developments with multiple buildings, parking areas shall be accessed through a network of internal streets.

2.4.6.2 TOWNHOUSE INTERNAL CIRCULATION

In townhouse developments, internal circulation shall be via one or more internal streets connecting to alleys where garages are located;

For clusters of detached garages, the internal streets or alleys must provide direct access to the rear parking lots, ensuring safe and efficient vehicular movement.

2.4.6.3 STRUCTURED PARKING ACCESS

1. Any vehicular entry gate to a parking structure that faces the sidewalk shall be located to provide a minimum of 25 ft. between the gate and the back of the sidewalk, ensuring sufficient space for larger vehicles to queue without encroaching on the pedestrian walkway. This distance minimizes conflicts between pedestrians and vehicles waiting for gate access. Additionally, for surface parking or visitor parking, driveway gates must also meet this setback requirement to ensure safe pedestrian circulation.
2. A parking structure shall not occupy more than 50% of the building width of any street-facing façade, and it shall be recessed a minimum of 5 ft. from the street-facing façade of the building.
3. One pedestrian gate shall be provided for each vehicular access gate to the parking structure.

2.5 BICYCLE CIRCULATION & PARKING

INTENT

- Ensure that bicycle parking facilities are secure, accessible, and conveniently located to encourage cycling, minimize conflicts with pedestrians and vehicles, and enhance the overall functionality of the development.
- Integrate bicycle parking into site design to minimize visual impact, maintain architectural consistency, and provide protection from the elements, supporting both short-term and long-term bicycle parking needs.

2.5.1 BICYCLE PARKING

2.5.1.1 SHORT-TERM BICYCLE PARKING

1. Short-term bicycle parking shall consist of racks that support the bicycle frame at two points and allow for the bicycle frame and one wheel to be locked to the rack with a U-lock. The racks shall be permanently secured to the ground
2. Short-term bicycle parking space shall be located within 200 ft. of a visitor entrance and visible to passers-by.
3. Short-term parking requires permanently anchored racks for 5% of visitor vehicle spaces, with a minimum of two spaces.
4. If more than twenty (20) short-term bicycle spaces are provided, at least 50% must be covered by a solid-roofed structure with a minimum height of 10 ft. and a 1.5-ft. overhang beyond the spaces.

2.5.1.2 LONG-TERM BICYCLE PARKING

Long-term bicycle parking facilities consists of bicycle lockers or bicycle rooms with key access for use by residents.

1. Long-term bicycle parking facilities shall be located on the ground floor or accessible from the street. These facilities shall be covered and lockable, either inside bike lockers, or in lockable bike rooms.
2. Multi-family residential and mixed-use buildings shall provide at least one long-term bicycle storage space per two dwelling units. The space may be located within the unit, in individual lockable containers outside the unit, or within a secure long-term bicycle parking area. However, dwelling units with individual garages shall not be required to provide long-term bicycle parking.

3. Secure, long-term bicycle parking areas shall be enclosed and designed within a parking structure or building, or within a lockable storage enclosure
 - a. Lockable storage enclosures shall not be visible from the right-of-way.
 - b. Enclosures must be constructed with solid walls and designed using materials and colors that match those of the primary building. Alternatively, enclosures may be screened from view by dense evergreen shrubs and trees, provided the screening fully obscures the enclosure from sight.
4. Bicycle locker minimum requirements:
 - a. Dimensions of 42 in. wide, 75 in. deep, and 54 in. high.
 - b. The top of the bicycle locker shall withstand a load of 200 pounds per square foot to ensure durability and safety.
 - c. Opened door must be able to withstand a 500-pound vertical load without damage to the door or locker.
5. Bicycle rooms with key access minimum requirements:
 - a. Bicycle rooms shall have a minimum ceiling height of 10 ft.
 - b. Bicycle rooms shall contain permanently anchored racks that support the bicycle frame at two points and allow for the bicycle frame and one wheel to be locked to the rack with a U-lock.
 - c. Long-term bicycle parking spaces shall be served by an aisle with a minimum width of 6 ft.
 - d. All bike racks shall be large enough to accommodate a 4-inch “fat tire” width.
 - e. There shall be at least 2 ft. of clear space between the aisle and the long-term bicycle parking spaces to allow adequate room for users to easily access and move their bicycles in and out of the racks.

2.6 PEDESTRIAN ACCESS & CIRCULATION

INTENT

- Create safe paths of travel for pedestrians to/from access buildings’ ingress/egress points.
- Minimize pedestrian interaction with vehicular paths of travel.

2.6.1 PEDESTRIAN PATHWAYS

1. All on-site buildings, entries, facilities, amenities, and vehicular and bicycle parking areas shall be internally connected with a minimum 4 ft. wide pedestrian pathway or pathway network that may include use of the public sidewalk. The pedestrian pathway network shall connect to the public sidewalk along each street. The connection to the public sidewalk shall be the shortest distance between the primary entry and sidewalk, and shall not be more than 125% of the straight-line distance.
2. For multi-family and mixed-use developments, pedestrian pathways within internal parking areas shall be separated from vehicular circulation by a physical barrier, such as a grade separation or a raised planting strip, of at least 6 inches in height and at least 6 ft. in width. A pedestrian pathway is exempt from this standard where it crosses a parking vehicular drive aisle. Additionally, ADA paths of travel inside parking structures are exempt from this requirement.
3. Pedestrian pathways shall be clearly paved to ensure visibility and consistency.
4. The use of asphalt for a pedestrian path is prohibited.
5. Pedestrian pathways shall maintain a minimum of 4 ft. of clear zone from buildings, private open space areas, and parking lots, except where the pathway provides direct access to these spaces.
6. Pedestrian pathways shall meet Americans with Disability Act (ADA) accessibility standards.
7. For every 200 ft. of pedestrian path, a minimum of two amenities that include trellises, benches, and/or trees shall be provided for rest or shade.

2.7 SITE LIGHTING

INTENT

- Create safe, welcoming, well-lighted areas, including building entries, pedestrian pathways and plazas, parking lots and vehicle maneuvering areas; and minimize excessive illumination on adjoining properties.

2.7.1 NUISANCE PREVENTION

All lights shall be directed, oriented, and shielded to prevent light trespass or glare onto adjacent properties. No spillover shall be permitted. The light level at property lines shall not exceed 0.3 foot-candles using 90 degrees cutoff downlights.

2.7.2 FIXTURE TYPES

All luminaires shall meet the most recently adopted criteria of the Illuminating Engineering Society of North America (IESNA) for “Cut Off” or “Full Cut Off” luminaires.

2.7.3 MINIMUM LIGHTING REQUIREMENTS

2.7.3.1 PARKING AREAS

1. Lighting in parking, garage, and carport areas shall be maintained with a minimum of one foot-candle of illumination at the ground-level during hours of darkness, with a maximum of seven foot-candles.
2. All lighting shall be controlled by a timeclock or photo-sensor system. Parking lot lighting shall be designed and installed with fixtures that direct light downward and away from surrounding buildings and properties, using full cut-off fixtures to minimize light trespass and glare.
3. Illumination color temperature shall be within the range between 3,000K - 5,000K.

2.7.3.2 MULTI-UNIT RESIDENTIAL DEVELOPMENTS

Aisles, passageways, and entryways/recesses within the building complex shall be illuminated with an intensity of at least 1 foot-candle at ground level during the hours of darkness, with a maximum intensity of 5 foot-candles to avoid excessive brightness and glare.

2.7.3.3 NON-RESIDENTIAL DEVELOPMENTS (OR PORTIONS OF A DEVELOPMENT)

1. All exterior doors, including utility doors, shall be illuminated with a minimum of 1 foot-candle of light during the hours of darkness, ensuring sufficient visibility for safety and security.
2. Exterior lighting for non-residential uses shall be appropriately designed, located, and shielded to ensure that they do not negatively impact the residential uses in the development nor any adjacent residential uses. All exterior lighting shall be 90 degrees cutoff downlights with illumination not to exceed 0.3 foot-candles. The rays of any such lighting shall be confined to the property. No spillover shall be permitted.

2.7.3.4 PEDESTRIAN SAFETY

Areas used by pedestrians shall be illuminated whenever natural light levels fall below 10 foot-candles to ensure safety. This applies during nighttime or in interior spaces, where natural lighting may be insufficient to maintain visibility. Such areas include:

- a. Surface parking lots and parking structures (entrances, elevators, and stairwells)
- b. Sidewalks, walkways, and plazas
- c. Building entrances (including rear and service entrances)
- d. Garbage disposal areas
- e. Alleys
- f. Automated Teller Machines (ATMs)
- g. Along property lines where there is an abutting public sidewalk

Lighting shall be low mounted and downward casting in a manner that reduces light trespass into adjacent properties.

2.7.4 DESIGN OF FIXTURES

2.7.4.1 BUILDING FIXTURES

All lighting shall be fully shielded, directed downward, and shall not spill beyond the intended area. Exterior lighting shall utilize low-glare, low-light pollution fixtures to ensure an efficient distribution of light for building exteriors and surrounding areas.

2.7.4.2 ACCENT LIGHTING

1. Architectural features may be illuminated by up-lighting, provided that the lamps are fully shielded to prevent light spill or upward light trespass, and the lighting intensity is appropriate to the scale of the building. Up-lighting should be directed to highlight features without causing glare or illuminating beyond the intended area.
2. All accent lighting plans shall be submitted to the City for review and approval during the building plan review process, ensuring that the fixture scale aligns with the massing and design of the building façade.

2.7.5 ENERGY EFFICIENCY

Outdoor lighting shall utilize energy-efficient fixtures and lamps, such as metal halide, LED or other lighting technology with a minimum luminous efficacy of 100 lumens per watt. All new outdoor lighting fixtures shall have a rated average bulb life of at least 30,000 hours, with at least 70% lumen maintenance level.

THIS PAGE LEFT INTENTIONALLY BLANK

BUILDING DESIGN

- 3.1 MASSING
- 3.2 BUILDING ORIENTATION
- 3.3 NEIGHBORHOOD TRANSITION
- 3.4 FAÇADE DESIGN
- 3.5 GROUND FLOOR USES
- 3.6 END UNITS
- 3.7 WINDOW ALIGNMENT
- 3.8 STREET FACING TRANSPARENCY
- 3.9 ENTRY TYPOLOGIES
- 3.10 ACCESSORY STRUCTURES ON RESIDENTIAL PROPERTIES
- 3.11 ACCESSORY DWELLING UNITS
- 3.12 UTILITIES, SERVICE AREAS & BUILDING EQUIPMENT



3

PURPOSE

- To mediate the scale, massing, and bulk of buildings to reflect a human scale, enhance the pedestrian experience and respond to a building's context through refined building massing and façade articulation.
- To set standards for transitions to lower scale development
- To incorporate passive green design elements, and promote unique placemaking.

3.1 MASSING

INTENT

- Encourage the use of building modulation, architectural roof forms, and strategic architectural projections to create visually appealing, cohesive, and well-articulated four-sided architecture.
- Ensure that the tops of buildings are designed with architectural interest, and to reduce the bulk of buildings as they meet the sky.
- Ensure that buildings are consistent in scale, mass, and character with adjacent buildings on lower density land uses and designated land use types
- Provide rooflines and massing that emphasize and accentuate significant elements of the building such as entries, bays, and balconies, and shading elements where appropriate.
- Provide harmonious transitions between adjacent properties where composition of building height, setbacks, and length of building reduces towards the existing scale and sizing of adjacent single family homes.
- Reinforce the definition and importance of the street

3.1.1 BUILDING TYPE STANDARDS

Specific Building Design standards are provided by the type and size of buildings in the Massing section of the Objective Design Standards. Although each building type has a maximum prescribed height, the maximum building height governed by the zoning district shall prevail. The name and definition of building types are as follows:

- **(S)** Small - Single-family or single-family attached
 1. Up to three (3) stories
 2. Maximum height of 35 ft.
 3. Maximum length of 100 ft. on any side
 4. Building types include single-family detached homes, detached residential clusters or two (2) unit single-family attached homes.
- **(M)** Medium – Multiplex and Mixed-Use Buildings
 1. Two (2) stories or greater
 2. Maximum height of 50 ft.
 3. Maximum length of 100 ft. on any side
 4. Building types include triplexes, fourplexes, unit(s) above commercial, or combinations of these types.
- **(L)** Large – Multiplex and Mixed-Use Buildings
 1. Two (2) stories or greater
 2. Maximum height of 50 ft.
 3. Length exceeding 100 ft.
 4. Building types include townhouses/rowhouses, walk-up multi-plex buildings, garden style apartments, or units above commercial

3.1.2 MASSING STRATEGIES

Buildings shall follow the minimum quantity of the massing strategies

1. Modulation,
2. Roof form, or
3. Projections, per the table below:

MASSING STRATEGIES

BUILDING TYPE	MINIMUM REQUIRED STRATEGIES
(S) SMALL	2
(M) MEDIUM	3
(L) LARGE	3

■ REQUIRED

● OPTIONAL

STRATEGIES	BUILDING TYPE		
	(S) SMALL	(M) MEDIUM	(L) LARGE
MODULATION	■	■	■
ROOF FORM	●	■	■
PROJECTIONS	●	■	■

TABLE 3.1: MASSING STRATEGIES TABLE

3.1.3 BUILDING MODULATION

3.1.3.1 MASSING BREAKS

Minor and major massing breaks are required for elevations that face a public street, pedestrian-oriented space, or a publicly accessible outdoor space. This can be created using insets, bays, notches or protrusions.

- 1. Minor Massing Break:** A minor massing break shall be applied at least every 60 ft. in horizontal building length. The minor break shall be a minimum of 1 ft. deep and 4 ft. wide, open to the sky, and extend the full height of the building.
- 2. Major Massing Break:** A major massing break shall be applied at least every 100 ft. in horizontal building length. The major break shall be a minimum of 3 ft. deep and 6 ft. wide, open to the sky, and extend the full height of the building.

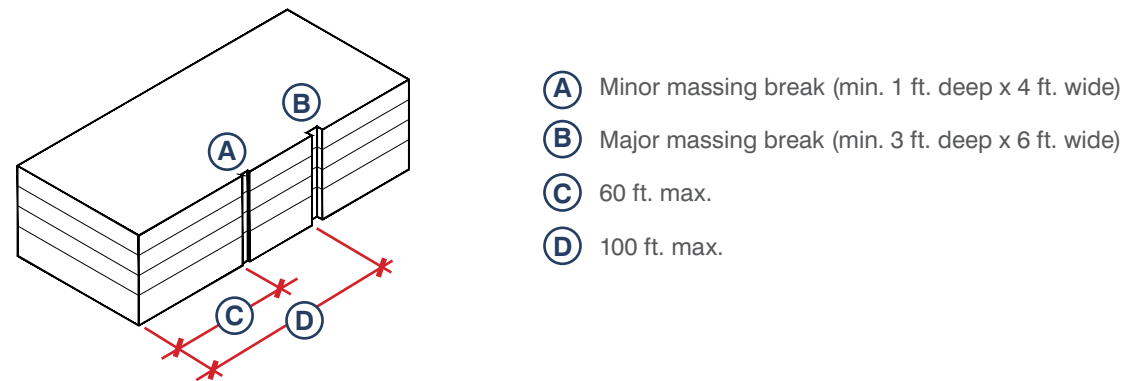

- (A) Minor massing break (min. 1 ft. deep x 4 ft. wide)
- (B) Major massing break (min. 3 ft. deep x 6 ft. wide)
- (C) 60 ft. max.
- (D) 100 ft. max.

FIGURE 3.1: BUILDING MODULATION

3.1.3.2 MAXIMUM CONTINUOUS UNINTERRUPTED BUILDING LENGTH

Buildings over 400 ft. in length, apart from applying the minimum required massing breaks, shall apply a horizontal plane change (open to the sky) of at least 50 ft. in depth when it reaches 400 ft. in length. For this plane change, the total linear horizontal length (A+B+C) shall not be less than 200 ft., shown in figure 3.2.

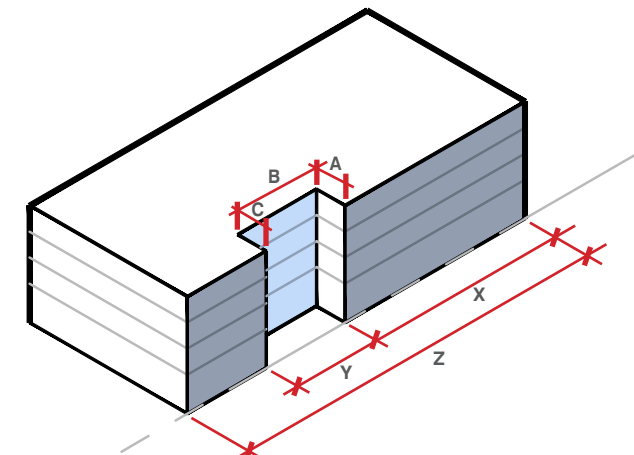

- X = MAXIMUM 400 ft. CONTINUOUS UNINTERRUPTED BUILDING LENGTH
- Y = HORIZONTAL PLANE CHANGE
- Z = TOTAL BUILDING LENGTH

FIGURE 3.2: MAXIMUM CONTINUOUS UNINTERRUPTED BUILDING LENGTH

3.1.3.3 MAXIMUM BUILDING LENGTH

The maximum length of a building in any direction shall be 700 ft.. The total building perimeter length shall not exceed 2,300 ft..

3.1.3.4 EXEMPTIONS

1. Building elevations that are less than 60 ft. in length are not required to have a change in plane incorporated into their design.
2. Stacked balconies with a minimum depth of 5 ft. and a minimum length of 8 ft., when applied to at least 80% of the upper floors can count as a minor massing break as long as: a) the railing is at least 70% see-through or transparent and goes all the way across the 8 ft. minimum length and; b) the parapet does not go all the way through the balcony. It will not qualify as a replacement for a major massing break which is open to the sky and extends to the full height of the building.

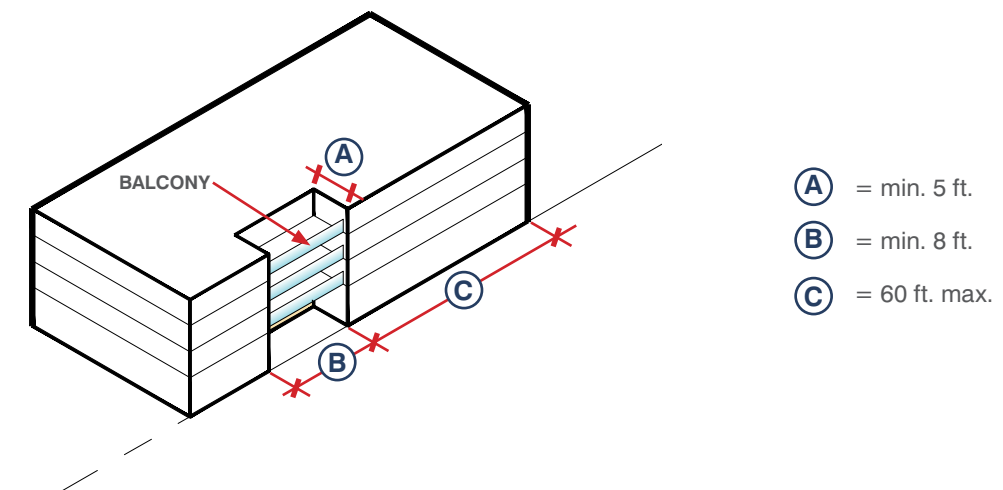

- (A) = min. 5 ft.
- (B) = min. 8 ft.
- (C) = 60 ft. max.

FIGURE 3.3: STACKED BALCONIES AS A MINOR BREAK

3.1.4 ROOF FORM

Variation in roof forms are required for elevations that face a public street, pedestrian-oriented space, or a publicly accessible outdoor space. For every 40 ft. of frontage, at least one (1) roof form is required.

3.1.4.1 METHODS TO CREATE ROOF FORM VARIATION

A change in roof form shall be implemented using one (1) or a combination of the following methods:

1. A change in roof type. Introduce a variation of roof styles (e.g., gable, hip, shed, etc.) to create a unique roofline and diverse building massing.
2. Change in roof height of at least 18 inches measured from the highest point of each roof line.
3. Stacked balconies as defined in Section 3.1.3.4
4. Stacked projecting balconies with a minimum depth of 5 ft. and a minimum length of 8 ft., when applied to at least 50% of the upper floors. The full balcony length shall project a minimum of 18 inches from the primary building facade.
5. Rooftop terrace with a minimum floor area of 80 sq. ft.
6. Providing architectural features such as dormers, chimneys, belfries, and porticos.
7. A change in roof pitch or direction.

3.1.4.2 CALCULATING ROOF FORMS

This section requires that 40 ft. is the maximum permitted continuous length of facade that may have a single roof form. The rule is focused on limiting the length of a single roof element, not on the total count of roof forms along the entire building length.

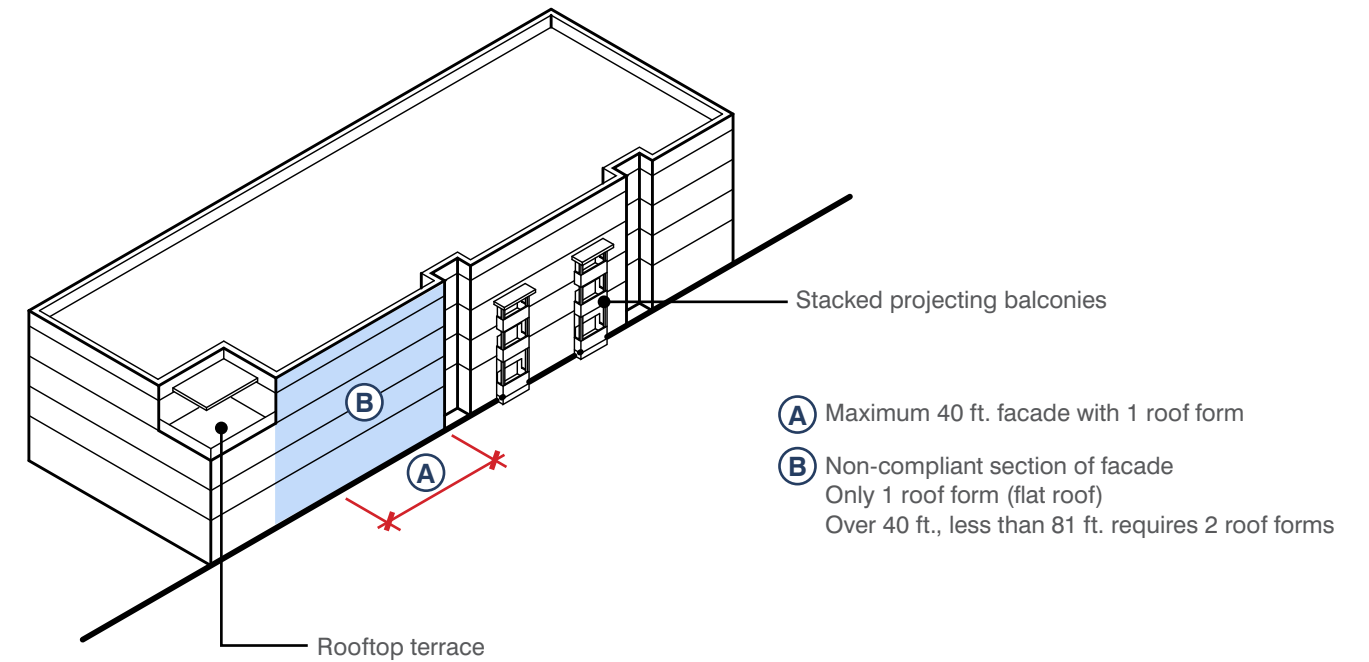

FIGURE 3.4: BUILDING FACADE WITH NON-COMPLIANT SECTION

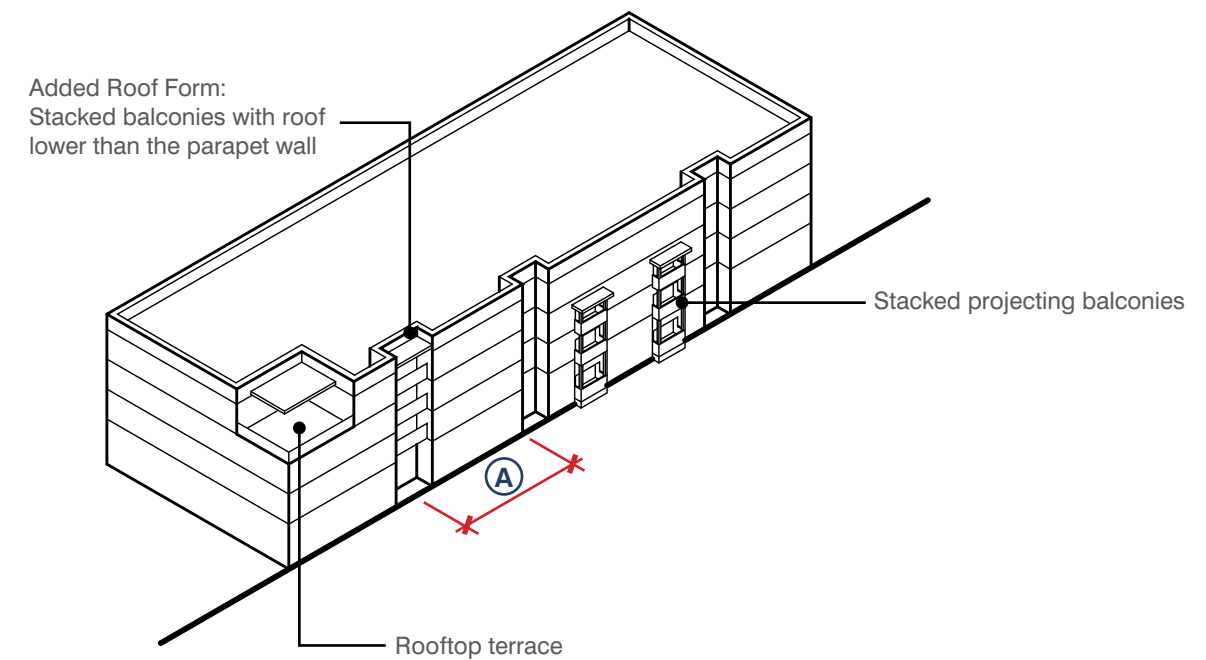

FIGURE 3.5: COMPLIANT BUILDING FACADE

3.1.4.3 CALCULATING COMBINED ROOF FORMS

1. The required number of roof forms may intersect to create more complex roof forms or may be organized in a hierarchy. Where two (2) or more roof forms are organized in a hierarchy, each is counted as an individual roof form. For example, the dominant roof form may be a hipped roof, which has two dormers with open gable roofs, which would count as three roof forms.
2. Where two (2) or more forms intersect or combine to create more complex forms, each is counted as an individual roof form. For example, two (2) hipped forms may intersect to create a hip and valley form, which would count as two (2) roof forms.
3. Roof forms may be repeated, such as a series of gables/hip on a pitched roof or a flat roof that steps up or down, or a “sawtooth.”

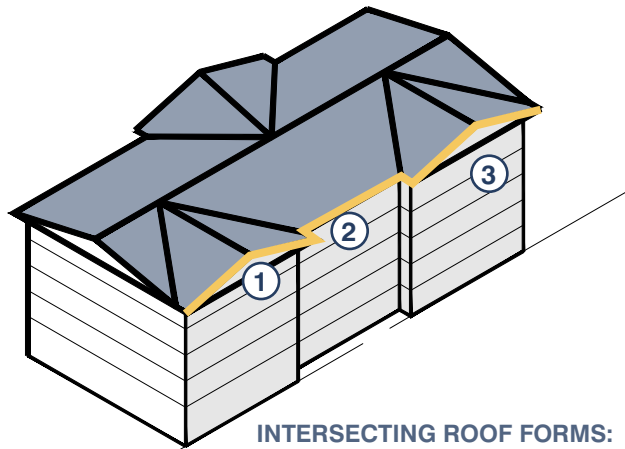

FIGURE 3.6: ROOF FORMS COMBINATIONS & QUANTITIES DIAGRAM 1

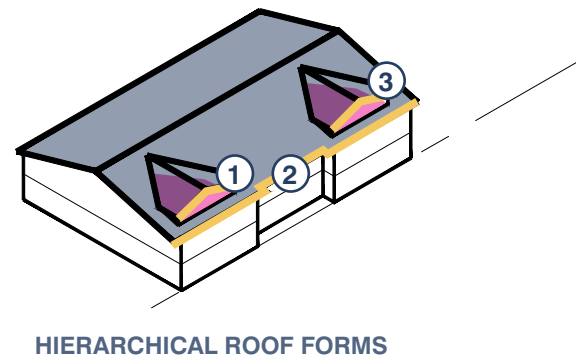

FIGURE 3.7: ROOF FORMS COMBINATIONS & QUANTITIES DIAGRAM 2

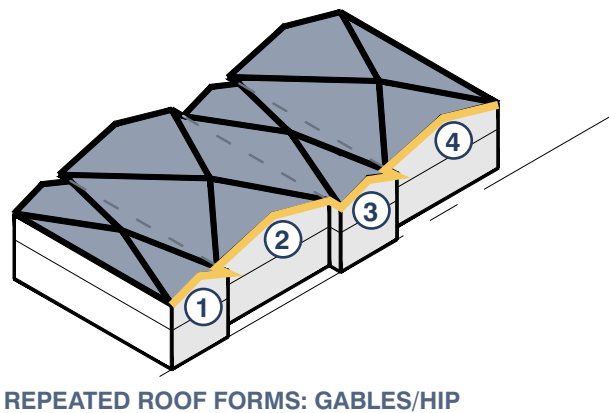
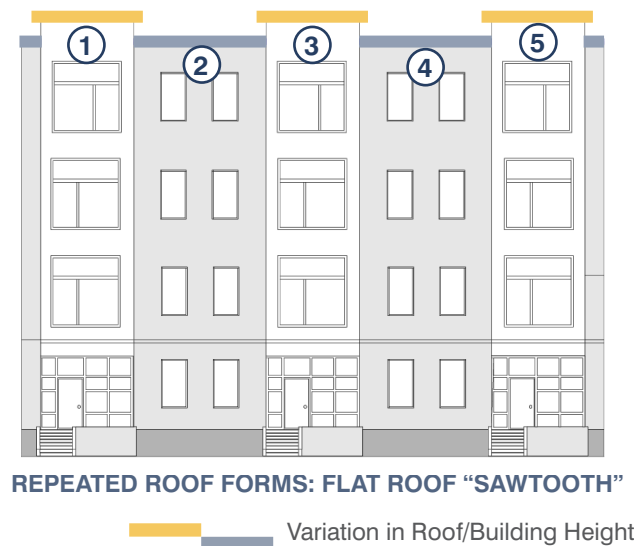

FIGURE 3.8: ROOF FORMS COMBINATIONS & QUANTITIES DIAGRAM 3



REPEATED ROOF FORMS: FLAT ROOF “SAWTOOTH”
 Variation in Roof/Building Height

3.1.4.4 ACCEPTABLE ROOF FORMS / TYPES

Roof form is defined as a geometric plane or set of planes which form the top enclosure of a volumetric area below it/them. Common types of roof forms are gabled, hipped, sloped, flat, and flat with a decorative parapet, among others. See below for acceptable roof forms for residential and mixed-use architecture in the City.

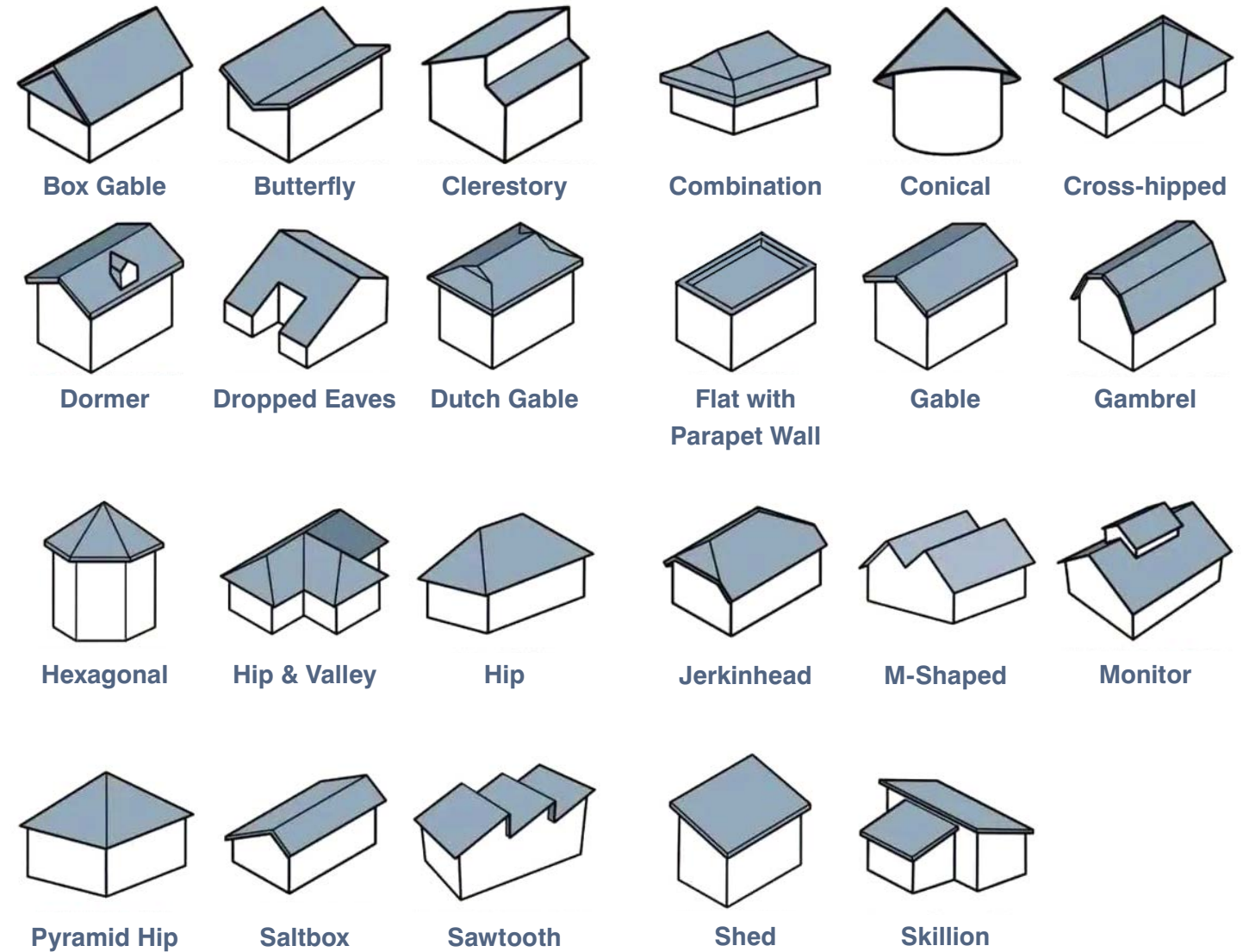

FIGURE 3.9: BUILDING ROOF FORM OPTIONS

3.1.4.5 NOTES

Changes in roof form shall not exceed allowable building heights, as defined in the San Fernando Zoning Ordinance.

3.1.5 BUILDING PROJECTIONS

Buildings shall use one (1) or more of the following projections:

1. Porches (See Building Entry Types)
2. Balconies and decks shall not project more than 6 ft. from the façade on elevations facing a street or public right-of-way.
 - a. The distance between supporting columns, piers, or posts on trellises or balconies shall not exceed their height.
3. Awnings or Canopies
 - a. For buildings with ground floor commercial uses, awnings shall be provided over each storefront, located within the individual structural bays.
 - b. Awnings and canopies shall not project more than 6 ft. from the façade.
 - c. The height of all awnings above the sidewalk shall be consistent, with a minimum clearance of 8 ft. provided between the bottom of the valance and the sidewalk. Valances shall not exceed 18 inches in height.
 - d. If used, lighting for awnings shall be from fixtures located above the awnings. Backlighting of transparent or translucent awnings are not allowed.

3.2 BUILDING ORIENTATION

INTENT

- Promote consistent development patterns along streets, particularly by how buildings relate to the street, to promote a sense of visual order, and provide attractive streetscapes.
- Configure buildings to provide “outdoor rooms,” including, but not limited to courtyards, paseos, and promenades.
- Locate building access points along sidewalks, pedestrian areas, and bicycle routes, and include amenities that encourage pedestrian activity.

3.2.1 BUILD-TO-ZONE

Buildings shall occupy a minimum percentage of the Build-to-Zone. The Build-to-Zone is defined as a specific distance beyond the building setback from the front property line, excluding areas for Primary Connections, Secondary Connections, or Public Open Space.

BUILD-TO-ZONE

	R1	D (Mixed-Use)	D (100% Residential) / R2 / R-3 / M / GN / MUC
BUILD-TO-ZONE DEPTH	N/A	0	10 ft., as measured from the front setback line
MINIMUM REQUIRED BUILDING WIDTH IN BUILD-TO-ZONE	N/A	100%	50% of building frontage

TABLE 3.2: BUILD-TO ZONE TABLE

KEY

M = Maclay District; D = Downtown District; GN = General Neighborhood District; MUC = Mixed-Use Corridor District

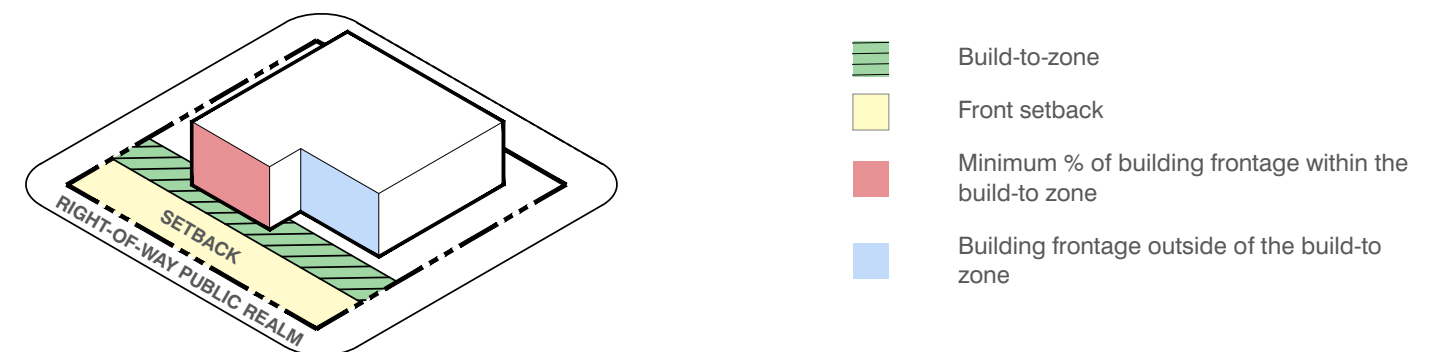

FIGURE 3.10: BUILD-TO ZONE DIAGRAM

3.2.2 BUILDING SITING AND ORIENTATION

Buildings shall be sited to define the street edge in the Downtown, Maclay, Workplace Flex Districts, and General Neighborhood Districts by establishing a continuous and strong building wall along their primary street frontages.

- a. For the Downtown District buildings shall orient towards their primary street frontage, fronting either Maclay Avenue, Truman Street, or San Fernando Road. Where a parcel has frontage on both Truman Street and San Fernando Road, buildings shall front San Fernando Road.
- b. For the Maclay District buildings shall orient towards Maclay Avenue.
- c. For the Workplace Flex District buildings shall orient towards First Street.
- d. For the Downtown District where the frontages of buildings are required to be built to the property line, where portions of the building frontage are recessed for entryways, recessed areas shall be treated as part of the public sidewalk, with special design elements, detailing and paving.
- e. Building frontages shall not orient to parking lots at the sides or rears of buildings.
- f. Building facades along the primary street frontage shall contain elevations activated by doors and windows that look into the street and shall contain the most articulated elevations of the building. Commercial frontages shall be public in nature and open to view from the street.

3.2.3 CORNER BUILDINGS

For multi-family residential and residential mixed-use developments located in the Downtown, Mixed-Use Corridor, and Maclay districts and along Hubbard Avenue in the Workplace Flex district, buildings located at intersections shall be designed to define and give prominence to the corner on which they are sited, by acknowledging both street facades with facade articulation and detail. At least one (1) of the following techniques shall be used.

- a. Creation of a landmark roof form, such as dome, conical or pyramidal roof.
- b. Creation of a corner tower with a special roof.
- c. A storefront, building protrusion, bay, porch element or arcade that wraps around the corner.
- d. A corner entrance that protrudes or is cut-away from the corner.
- e. A change in roofline; such as a gabled end to mark the corner.

3.2.4 MAIN ENTRANCE

1. Entrances shall be designed to be consistent with the overall architecture of the building. At all buildings (except for multifamily buildings up to eight (8) units and not exceeding 40 ft. in width along its primary street frontage), entrances shall be located along the primary street facade and shall be clear, easily identifiable and shall use one (1) or more of the following treatments.
 - a. Marked by a taller mass above, such as a modest tower, or within a volume that protrudes from the rest of the building surface.
 - b. Indicated by a projection from the building facade, and covered by means of a building overhang, awning or canopy that projects from the building.
 - c. Indicated by a recessed entry. Treatments shall include either special paving materials such as ceramic tile; ornamental ceiling treatments, such as coffering; decorative light fixtures; and attractive decorative pulls, escutcheons, hinges, and other hardware.
 - d. Denoted by a single arch or series of arches to indicate entry. Arcaded entry porches are also recommended.
 - e. Framed by special architectural elements, such as columns, archways, and overhanging roofs.
 - f. Emphasized by a small roof overhang over the entrance, change in roofline or a major break in the surface of the subject wall.
2. When non-residential and residential uses are located in the same building, separate exterior pedestrian entrances, elevators and lobbies shall be provided for each use. Entrances to the residential upper story shall be clearly distinguishable in form and location from retail entrances, and shall use one (1) or more of the following treatments.
 - a. Accented by architectural elements that are “residential” in character, such as small windows above the door, sidelights, and ornamental light fixtures, front stoops or plantings.
 - b. Indicated by a recessed entrance, for example a vestibule or a lobby.
3. Each ground-floor unit that fronts the primary street frontage within residential and mixed-use residential buildings in the Maclay and Mixed-Use Corridor districts is required to have its own entrance facing the street. See Section 3.9.2 Building Entry Types for a list of permissible entry typologies.

3.2.5 PEDESTRIAN CONNECTION

1. Primary building or unit entries shall be connected to a public sidewalk or publicly accessible pathway. The connection shall be a pedestrian pathway with a minimum width as specified in the table:
2. For multi-family and mixed-use developments, the main building entry and common exterior spaces shall provide a minimum of one (1) pedestrian pathways/connections to any and all of the following areas:

PEDESTRIAN CONNECTIONS

	MINIMUM WIDTH
ENTRANCES SERVING 1-2 UNITS	4 ft.
ENTRANCES SERVING 3-8 UNITS	5 ft.
ENTRANCES SERVING >8 UNITS	6 ft.

TABLE 3.3: MINIMUM WIDTH REQUIREMENTS FOR PEDESTRIAN CONNECTIONS

- a. The public sidewalk in the right-of-way on each street frontage.
- b. The parking area serving the units.
- c. Any on-site common usable open space, recreational facilities, or public park facilities located on an adjacent lot.
- d. Any public multi-use pathways or trails abutting the project.
- e. Adjoining residential or commercial projects.

3.3 NEIGHBORHOOD TRANSITION

INTENT

- To create a transition between new development and existing neighborhoods, provide privacy for current and future residents, and minimize potential shading on neighboring residents.

For all project property lines that abut a single family residential neighborhood, the following shall apply.

3.3.1 TRANSITION PLANE

- a. Buildings shall not intercept a 45-degree neighborhood transition plane inclined inward from the underlying setback, starting at a height 35 ft. above grade.
- b. Private or shared balconies and decks shall not extend into an underlying setback.
- c. The occupied area of roof decks, including any deck on roof area falling under the neighborhood transition plane, shall be set back at least 3 ft. from the building edge and any railings, shade structures, or accessory structures shall not intersect the required neighborhood transition plane.

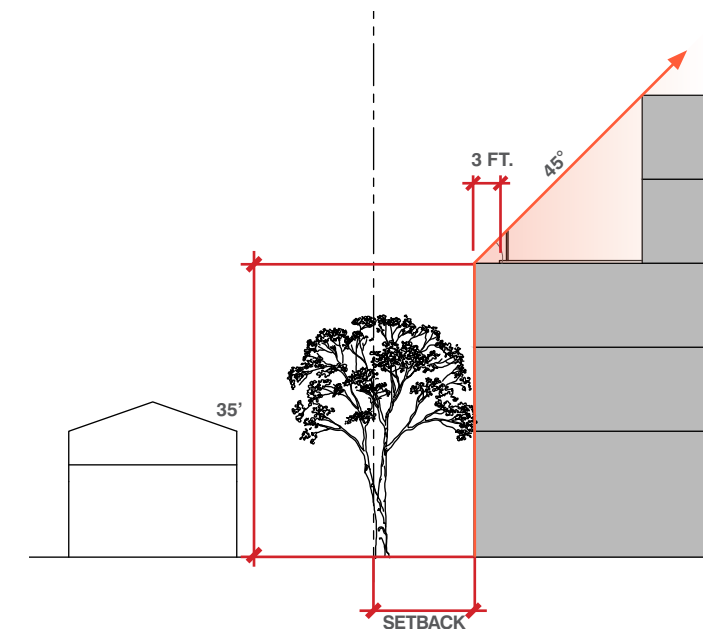

FIGURE 3.11: TRANSITION PLANE

3.4 FAÇADE DESIGN

INTENT

- To create cohesive and well-crafted building façades with human-scaled details that provide visual interest to pedestrians, incorporate passive green design elements, and promote high-quality design.
- Encourage architectural elements that contribute to a building’s character, aid in climate control, and enhance pedestrian scale.
- Encourage complementary architectural detailing that differentiates uses within a mixed-use building.

3.4.1 FAÇADE TREATMENT

For the purpose of this section, a change in facade treatment is defined as a change of material which can be combining different finishes, textures, or types of cladding (like glass, metal, stone, wood, concrete) on a building’s exterior to create visual interest, and add depth for a more layered look.

1. Each building façade greater than 60 ft. in length shall include a minimum of two (2) distinct façade treatments. For every additional 60 ft. of building façade, an additional one (1) distinct façade treatment is required up to a maximum of three (3) treatments. Additional treatments beyond the maximum are permitted and may be less than 20% of the overall facade area.
2. Each distinct façade treatment shall have a minimum of 20% of the overall façade area.
3. A change in stucco color may be considered a distinct facade treatment, allowing for up to two (2) variations of facade treatment.

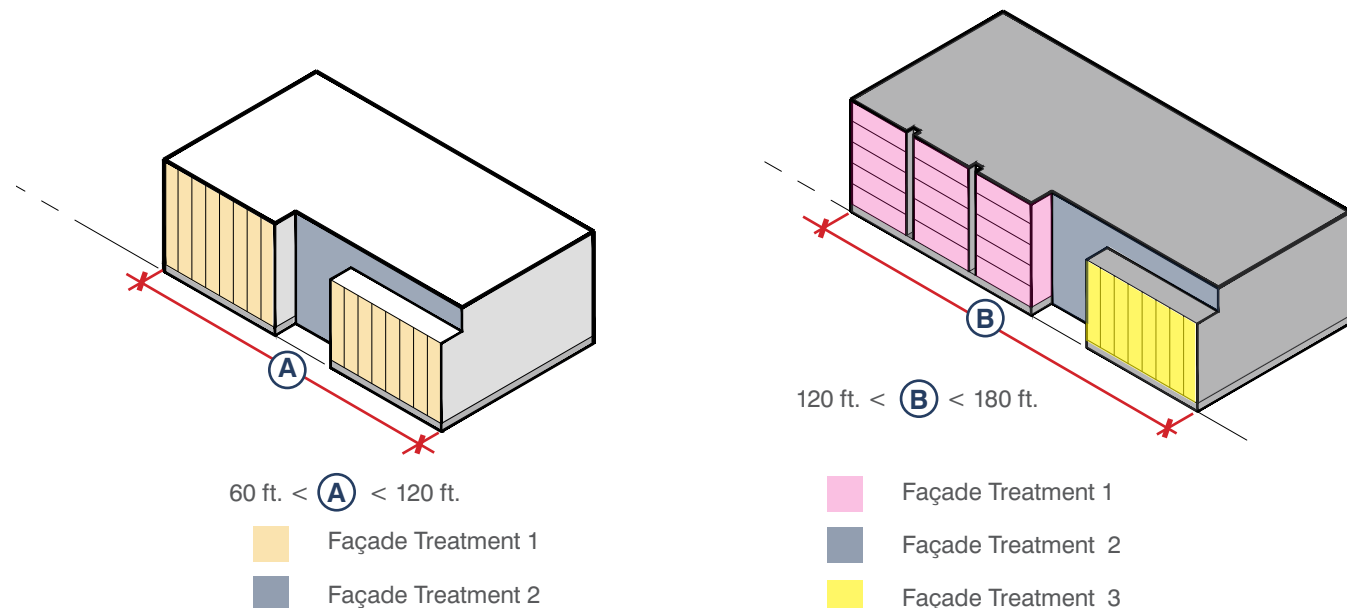

FIGURE 3.12: FAÇADE TREATMENT DIAGRAM 1

FIGURE 3.13: FAÇADE TREATMENT DIAGRAM 2

3.4.2 BASE/MIDDLE/TOP

1. Buildings four (4) stories or taller with a building length greater than 50 ft. shall be designed as specified in this subsection to differentiate a defined base or ground floor, a middle or body, and a top, cornice, or parapet cap. This standard applies to all exterior facing facades.
2. A building’s base shall be defined or differentiated from the middle/body by using one (1) of the following techniques:
 - a. Have a distinct façade composition between the base floor(s) and middle/body floors
 - b. Have a datum line or cornice between the base floor(s) and middle/body floors that:
 - Is a different material from the middle/body floors
 - Has a minimum height of 4 inches and a minimum depth of 4 inches.
 - c. Floor-to-floor ground floor height that is a minimum 2 ft. greater than middle/body floor-to-floor heights.

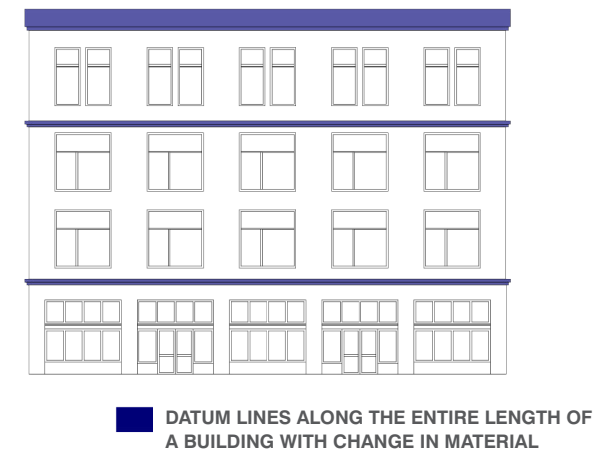

FIGURE 3.14: DATUM LINE DIAGRAM 1

3. A building's top floor(s) shall be defined or differentiated from the middle/body by using two (2) or more of the following techniques:
 - a. Have a distinct façade composition from the middle/body floors to the top floor(s)
 - b. Datum line or cornice between the middle and top floor(s) that include:
 - A change in material from the façade
 - A minimum height of 4 inches and a minimum depth of four 4 inches.
 - c. Distinct roof form or roof line. Apply one (1)
 - Cornice or parapet cap that includes a change in material from the façade and a minimum height of 8 inches and a minimum depth of four 4 inches.
 - Eave/roof overhang with a minimum depth of 6 inches.
 - A variation in roof/building height through building modulation: (examples: Bays that extend above Primary Façade height)

3.4.3 FACADE MATERIALS

1. Building Materials.
 - a. Brick veneers shall be mortared to give the appearance of structural brick. Brick veneer applications shall use wrap-around corner and bullnose pieces to minimize veneer appearance. An anti-graffiti coating shall be applied.
 - b. Stucco, cement plaster or stucco-like finishes are acceptable finishes. Attention should be paid to detail and trim elements for a high quality installation. Highly textured surface textures are prohibited. The pattern of joints shall match the overall facade composition, and sealant colors shall be consistent with surface and other building colors. Stucco surfaces shall have a smooth trowel finish and 1/2 to 3/4 inch bull-nosed corners. A light sand finish is acceptable. Rough texture, such as skip trowel or Spanish lace, is prohibited.
 - c. Wood: Horizontal sidings such as clapboard and tongue-in-groove, vertical siding such as board and batten, and other horizontal sidings such as smaller wood shingles and shakes are acceptable. The larger, more rustic styles of shingles and shakes shall not be used.

2. Windows.
 - a. Window frames shall not be set flush with walls. Glass shall be inset a minimum of 2 inches from the exterior wall and/or frame surface.
 - b. At deeply inset windows (greater than 4 inches from the exterior wall); the framing may be simple and relatively unarticulated. At shallower insets (2-4 inches from the exterior wall), projecting sills, molded surrounds, lintels and/or trim shall be used to frame openings.
 - c. Sills and surrounds shall be proportioned to relate to the window size. For windows less than 48 inches in width, surrounds shall not exceed 6" in width. For windows greater than 48 inches in width, surrounds shall not exceed 8 inches in width.
 - d. Aluminum sliding windows shall be designed to have substantial framing members, at a minimum width of 2 inches.
 - e. Clear glass is preferred. Reflective glazing shall not be used. Non-reflective films, coatings, low emissivity glass, and external and internal shade devices shall be used for heat and glare control.
 - f. Deeply tinted glass or applied films shall not be used. If tinted glazing is used, light tints and green, gray and blue hues are acceptable.
3. Roofs.
 - a. Flat roofs shall always be edged with parapet walls; and shall be treated with one (1) or more of the following conditions:
 - i. An architecturally profiled cornice and/or expressed parapet cap shall be used to terminate the top of parapet wall.
 - ii. Surface mounted cornices, continuous shade elements, or trellises shall be used to strengthen a parapet wall design
 - iii. A single layer, flush sheet metal parapet cap (for example a simple inverted U of sheet metal over the top of a parapet wall) without a substantial built-up edge shall not be used, as these installations often display warped sheet metal (oil canning) and a low-quality appearance. If used, sheet metal parapet caps shall provide formed (compound folded) overhanging edge termination and a heavy gauge sheet metal thickness selected to avoid oil-canning distortion.

3.5 GROUND FLOOR USES

As intended for multifamily and mixed-use projects in the Maclay, Downtown, Mixed-Use Corridor, and General Neighborhood districts; including the R-3 and Mixed-Use Overlay zones.

INTENT

- To create a coherent and active interface between private development and the public realm, which contributes to the sense of place and structure of the neighborhood, and enhances the public's experience.
- Promote consistent development patterns along streets, particularly in how buildings relate to the street, to promote a sense of visual order, and provide attractive streetscapes.
- Locate building access points along sidewalks, pedestrian areas, and bicycle routes, and include amenities that encourage pedestrian activity.

3.5.1 ACTIVE FRONTAGES

Active frontages are building frontages with active uses that visually engage between the street and the ground floor and generate significant pedestrian activity over extended periods of the day. Active frontages may be shops, cafes, restaurants, and other social spaces and may share accessory spaces such as lobbies, lounges and shared amenity areas.

1. Active frontage types shall consist of one (1) or more of the following ground-floor uses:
 - a. Storefront Commercial
 - b. Ground Floor Office
 - c. Live/Work
 - d. Ground Floor Residential Units with individual patios
 - e. Ground Floor Residential Accessory Spaces (e.g., indoor community spaces, permitted only in residential zones)

2. Active Frontages are required for a minimum of 60% of each building façade facing an arterial, a local or collector public street, a publicly accessible private street, or a publicly accessible pathway with adjacent Primary Building Frontages.

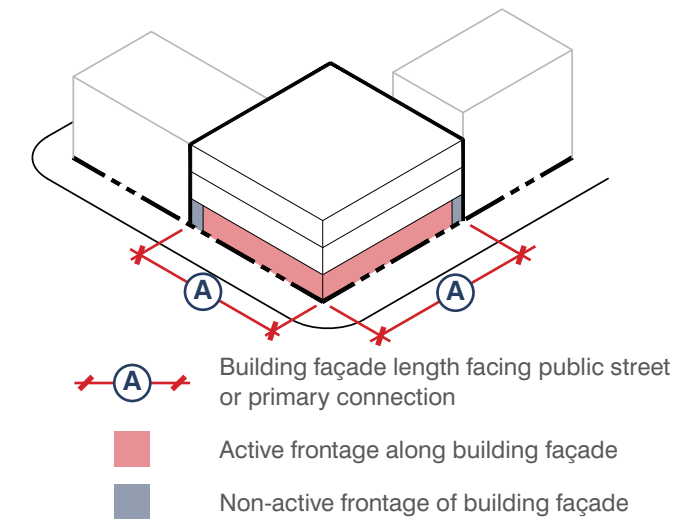

FIGURE 3.15: ACTIVE FRONTAGE DIAGRAM

3. On corner parcels, the non-residential use shall turn (wrap around) the corner for a distance of at least 30 ft., or at least 50% of the building façade, whichever is less. The termination of use shall occur at an architectural break in the building.

- To qualify as Active Frontage, uses shall meet the minimum depth requirements based on the use type as follows:

ACTIVE FRONTAGES MIN. USE DEPTH

		MIN. DEPTH	MIN. CORNER SPACE DEPTH
STOREFRONT COMMERCIAL	■	30 ft.	40 ft. on all sides
GROUND FLOOR OFFICE	■	30 ft.	
LIVE/WORK	■	15 ft./ 50% of the width of the use frontage (>15 ft.)	
GROUND FLOOR RESIDENTIAL UNIT W/ PATIO ¹	■	min. patio depth = 6 ft.	
GROUND FLOOR RESIDENTIAL ACCESSORY SPACES	■	20 ft.	

1. Patio width shall be at least of 50% of the unit width.

TABLE 3.4: ACTIVE FRONTAGE MINIMUM USE DEPTH STANDARD

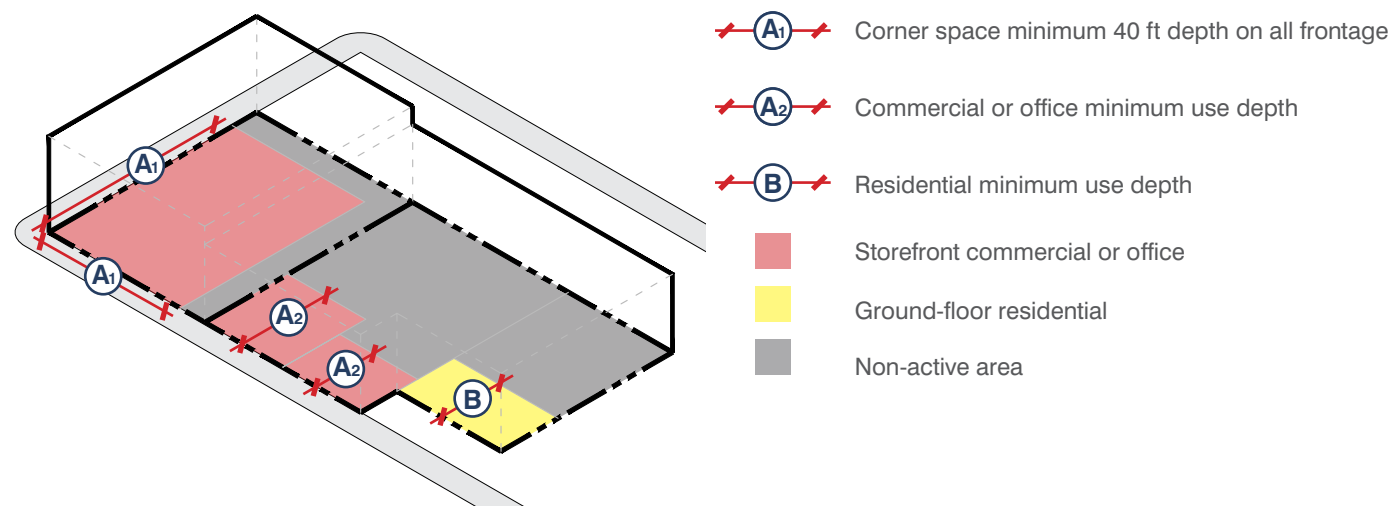

FIGURE 3.16: ACTIVE FRONTAGE MIN. DEPTH DIAGRAM

3.5.1.1 FINISHED FLOOR HEIGHTS OF ACTIVE USES

Active frontage spaces shall have a finished floor height within the following ranges (measured from grade at the back edge of the adjacent sidewalk). All other uses see Standard 3.5.1.2 Variable Finished Floor Height Standard.

ACTIVE USES FINISHED FLOOR HEIGHT

	MIN. HEIGHT (FT.)	MAX. HEIGHT (FT.)
PRIMARY BUILDING ENTRIES	0 ft.	3 ft.
STOREFRONT COMMERCIAL; LIVE/WORK; OFFICE	0 ft.	1 ft.
BUILDINGS WITH CROSS SLOPE	At no point shall the finished floor height be greater than 2 ft. above or below grade, with a minimum cross slope of 1%	

TABLE 3.5: ACTIVE USES FINISHED FLOOR HEIGHT STANDARD

3.5.1.2 VARIABLE FINISHED FLOOR HEIGHTS

To create a positive transition between the public and private realm, ensure the privacy of residential units, and maintain ‘eyes on the street’, see the standards as follow:

- The finished floor of ground-floor residential units adjacent to a public right-of-way shall be within the minimum and maximum heights specified based on the setback distance from the back of the sidewalk.
- For sites with a cross slope greater than 2% along the building façade, the average height between the finished floor and the back of the sidewalk shall be used.

3.5.1.3 FLOOR TO FLOOR HEIGHTS OF ACTIVE USES

Active Frontage uses shall have a minimum floor-to-floor height by use type as follows:

ACTIVE USES FLOOR TO FLOOR HEIGHT	MIN. HEIGHT (FT.)
STOREFRONT COMMERCIAL	15 ft.
GROUND FLOOR OFFICE	10 ft.
LIVE/WORK	
GROUND FLOOR RESIDENTIAL UNITS	
GROUND FLOOR RESIDENTIAL ACCESSORY SPACE	

TABLE 3.6: ACTIVE USES FLOOR TO FLOOR HEIGHT STANDARD

3.6 END UNITS

3.6.1 END UNITS STANDARDS

Medium and large-sized buildings with the Primary Façade and building entry facing a street or pathway perpendicular to a public street right-of-way, private street, or publicly accessible pathway shall meet the following standards:

1. The end unit building façade shall have a fenestration area greater than 15% of the façade area.
2. The end unit building façade shall have at least one (1) architectural projection that projects a minimum of eighteen 18 inches from the street facing façade (example: bay windows, a chimney shown on the exterior of the house) with a minimum width of 2 ft.
3. The location of an assigned surface parking stall may not exceed 50 ft. of an end unit’s ground floor façade.

3.7 WINDOW ALIGNMENT

3.7.1 WINDOW ALIGNMENT

Within single-family and multi-family buildings, windows facing each other and located within 40 ft. of each other shall not directly align with one another.

3.8 STREET FACING TRANSPARENCY

INTENT

- To provide visual interest along the public realm and promote natural surveillance by encouraging visual connections between the public realm and the interior of a building.
- Promote using transparent materials, such as glass, for artistic and decorative expression in buildings that promote health, well-being and comfort.

3.8.1 TRANSPARENCY

Placement and orientation of doorways, windows, and landscape elements shall create strong, direct relationships with the street. Street-facing facades of all buildings shall incorporate windows and openings providing light to adjacent spaces, rooms and uses. Transparency is measured as a percentage, calculated as the sum of single story transparent area divided by the total single story facade area.

Each applicable façade shall provide no less than the minimum transparency listed by use.

REQUIRED TRANSPARENCY BY FRONTAGE TYPE

FRONTAGE TYPE	TRANSPARENCY (MIN.)	
	GROUND LEVEL	UPPER LEVELS
STOREFRONT COMMERCIAL	50%	40%
SINGLE-FAMILY RESIDENTIAL	20%	10%
MULTIFAMILY RESIDENTIAL	30%	20%
GENERAL FRONTAGES ¹	40%	30%

¹ General frontages include offices, restaurants, markets, and any other uses that do not fall under the categories storefront commercial, single-family residential or multifamily residential.

TABLE 3.7: REQUIRED TRANSPARENCY BY FRONTAGE TYPE

3.8.1.1 COMMERCIAL STREET FRONTAGE TRANSPARENCY

Commercial use facades shall be comprised of windows and/or doorlites with clear unobscured glass as measured from 2.5 ft. to 8 ft. above finished grade where no minimum blank walls occur.

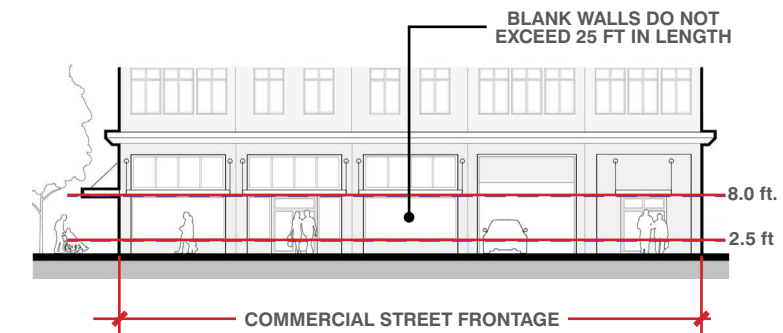

FIGURE 3.17: COMMERCIAL STREET FRONTAGE TRANSPARENCY

3.8.1.2 BLANK WALLS

1. Blank building facades shall be prohibited. Building facades without the use of windows or doors shall not span a continuous horizontal length greater than 25 ft. across any story.
2. A break in a blank building wall shall be provided by any of the following:
 - Doors, windows, or other building openings.
 - Varying wall planes, where the wall projects or is recessed at least 6 inches.
3. The following do not qualify as a break in blank wall:
 - Variation in exterior building wall color.
 - Stand-alone planted vegetation or landscaping not attached to a building wall.
 - Commercial, residential or directional signs.
 - Mechanical appurtenances such as water heaters, vents, or utility meters.

3.9 ENTRY TYPOLOGIES

INTENT

To set standards to create visual interest and placemaking through a building’s relationship to the public realm.

3.9.1 ENTRIES

For multifamily residential buildings with up to eight (8) units and not exceeding 40 ft. in width, the Primary Building Entry may be located on the side of the building not facing the public right-of-way if a publicly accessible pedestrian pathway connects directly to a forecourt or front porch with a minimum dimension of 6 inches in width.

3.9.2 BUILDING ENTRY TYPES

1. Primary building frontages for all residential buildings or mixed-use buildings shall face a public sidewalk or common area.
2. A minimum of one (1) of the following building entrance typologies shall be applied to any building frontage. Applicability is based on building type (S,M,L) per Section 3.1.1 of this chapter or use (mixed-use, etc.).
 - Porch
 - Dooryard
 - Stoop
 - Forecourt
 - Shopfront
 - Commercial Lobby
 - Arcade
 - Gallery
 - Residential ground floor patio
 - Residential accessory use

3.9.2.1 PORCH (S,M)

In the Porch Frontage Type, the main façade of the building is set back from the frontage line. The porch, which is a roofed and unenclosed room, open on three sides, provides a physical transition between the sidewalk and the building. They shall be on Primary and/ or Side Streets and may encroach into the front yard and side street yard (per Sec. 106-189 of the zoning code). Porches shall be spaced at least 6 ft. apart. All porches must have a flat, hipped or gabled roof or canopy.

The materials shall be compatible with the rest of the building. The front yard shall be landscaped. Paved areas shall be limited to walks and driveways. Porches may be enclosed with insect screens if recessed from the exterior wall plane and if visibility is maintained from the sidewalk.

FRONTAGES: PORCH SIZE

		(FT)
WIDTH	Ⓐ	12 MIN
DEPTH	Ⓑ	7 MIN
HEIGHT	Ⓒ	8 MIN / 12 MAX
FINISH LEVEL ABOVE SIDEWALK SEPARATION BETWEEN PORCH & SIDEWALK	Ⓓ	4 in. MIN / 3 MAX
	Ⓔ	5 MIN

TABLE 3.8: FRONTAGES: PORCH SIZE

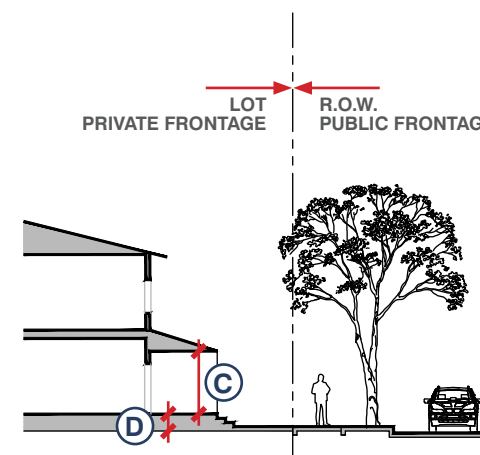

FIGURE 3.18: PORCH FRONTAGE SECTION

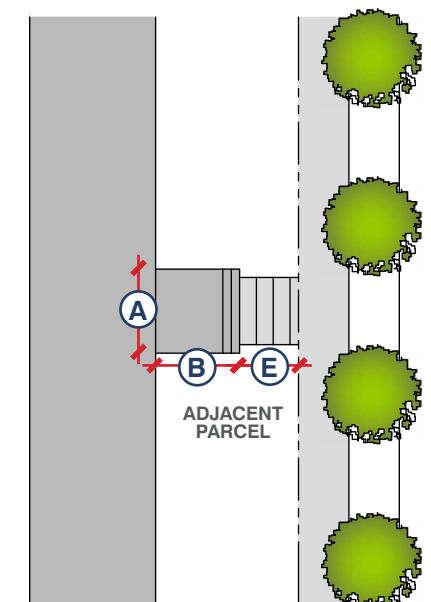

FIGURE 3.19: PORCH FRONTAGE PLAN VIEW DIAGRAM

3.9.2.2 DOORYARD (S,M,L)

In the Dooryard Frontage Type, the main façade of the building is set back from the frontage line, which is defined by a low wall or hedge, creating a small dooryard. The dooryard shall not provide public circulation along a ROW. The dooryard may be raised, sunken, or at grade and is intended for ground-floor residential.

For live/work, retail, commercial and service uses, these standards are to be used in conjunction with those for the Shopfront Frontage Type. In case of conflict between them, the Dooryard Frontage Type standards shall prevail. The Dooryard shall not be used for circulation for more than one (1) ground floor entry. Walls may extend an additional 2 ft. in height and fences or railings to the height required by the California Building Code (CBC).

FRONTAGES: DOORYARD SIZE

	(FT)
WIDTH	50 MAX.
DEPTH	8 MIN.
FINISH LEVEL ABOVE SIDEWALK	3 MAX.
FINISH LEVEL BELOW SIDEWALK	6 MAX.
PATH OF TRAVEL	4 WIDE MIN.

TABLE 3.9: FRONTAGES: DOORYARD SIZE

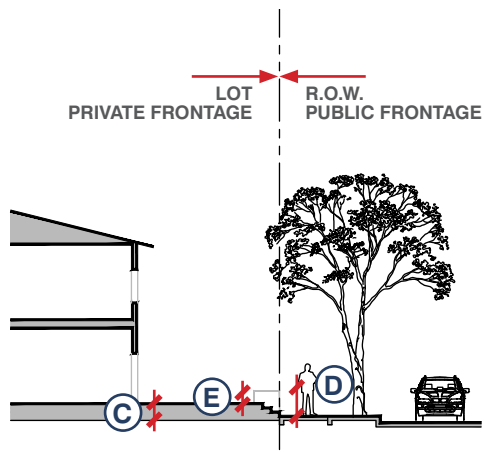

FIGURE 3.20: DOORYARD FRONTAGE SECTION

FRONTAGES: DOORYARD SIZE

	(FT)
WALL HEIGHT ABOVE ADJACENT SIDEWALK	4 MAX.
WALL HEIGHT ABOVE TERRACE FLOOR	3 MAX.
FENCE/ RAIL HEIGHT ABOVE TERRACE FLOOR	PER CBC

TABLE 3.10: FRONTAGES: DOORYARD SIZE

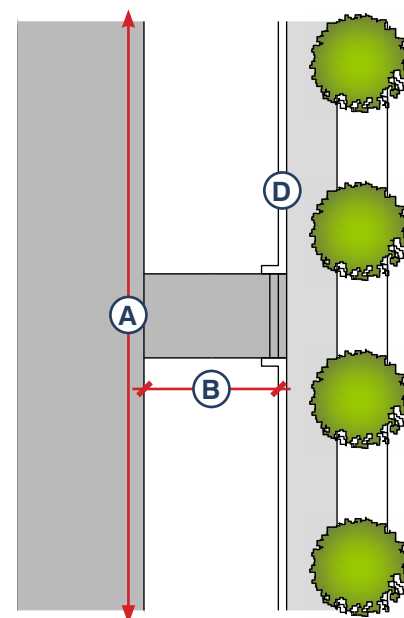

FIGURE 3.21: DOORYARD FRONTAGE PLAN VIEW DIAGRAM

3.9.2.3 STOOP (S,M,L)

In the Stoop Frontage Type, the main façade of the building is near the frontage line and the elevated stoop engages the sidewalk. The stoop shall be elevated above the sidewalk to ensure privacy within the building. Stairs or ramps from the stoop may lead directly to the sidewalk or may be side-loaded. Stairs may be perpendicular or parallel to the building façade. Ramps shall be parallel to façade or along the side of the building. The entry doors are encouraged to be covered or recessed to provide shelter from the elements. If stair access is parallel to sidewalk, the landscaping shall be provided between the stoop and the sidewalk, otherwise, landscaping should be placed on the sides of the stoop, either at grade or in raised planters. The ground floor of the building is raised to provide privacy for the rooms facing the public street. The landing may be covered or uncovered.

FRONTAGES: STOOP SIZE

	(FT)
WIDTH	4 MIN. / 10 MAX.
DEPTH	4 MIN. / 10 MAX.
FINISH LEVEL ABOVE SIDEWALK	18 in. MIN. / 3 MAX.
PLANTER/ FENCE HEIGHT	3 MAX

TABLE 3.11: FRONTAGES: STOOP SIZE

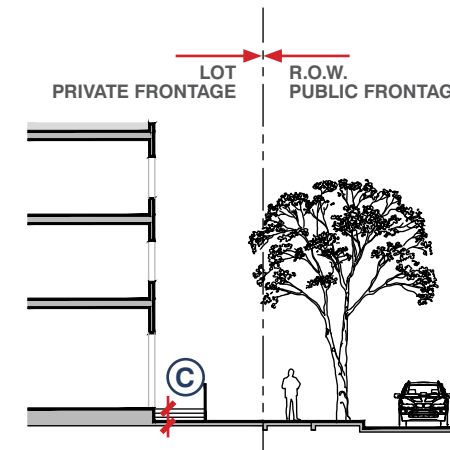

FIGURE 3.22: STOOP FRONTAGE SECTION

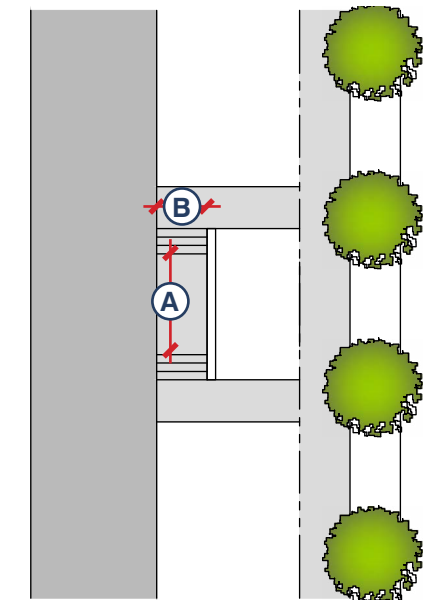

FIGURE 3.23: STOOP FRONTAGE PLAN VIEW DIAGRAM

3.9.2.4 FORECOURT (M,L)

In the Forecourt Frontage Type, the main façade of the building is at or near the frontage line and a small percentage is set back, creating a small court space. The space could be used as an entry court or shared garden space for apartment buildings, or as an additional shopping or restaurant seating area within retail and service areas. The proportions and orientation of these spaces should be carefully considered for solar orientation and user comfort.

FRONTAGES: FORECOURT SIZE

		(FT)
WIDTH	(A)	12 MIN.
DEPTH	(B)	12 MIN.
RATIO, BLDG. HEIGHT TO FORECOURT WIDTH		2:1

TABLE 3.12: FRONTAGES: FORECOURT SIZE

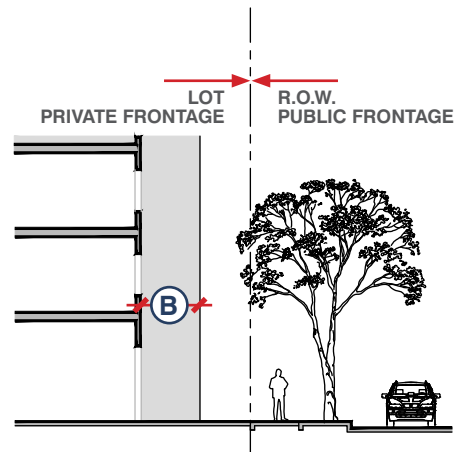

FIGURE 3.24: FORECOURT FRONTAGE SECTION

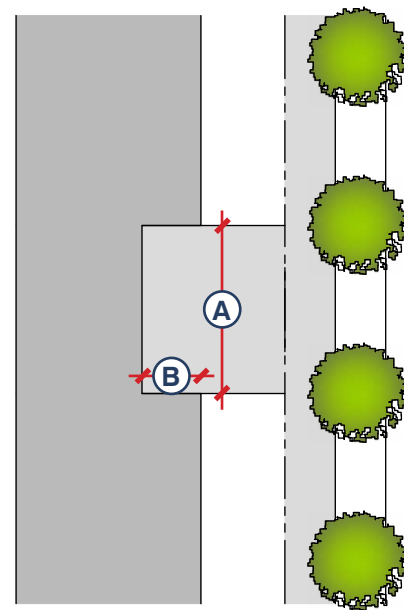

FIGURE 3.25: FORECOURT FRONTAGE PLAN VIEW DIAGRAM

3.9.2.5 SHOPFRONT (MIXED USE)

In the Shopfront Frontage Type, the main façade of the building is at or near the frontage line with an at-grade entrance along the public right-of-way. Shopfronts shall have large windows with glazing, doors with glass, and a storefront assembly. It shall include an awning or a canopy that may overlap the sidewalk, extending to a distance within 2 ft. of the face of curb. It may also include transom windows, a solid base (bulkhead), cantilevered shed roof, signage, lighting, and cornices. It may be used in conjunction with other frontage types. Primary Street and Side Street setbacks, if any, are to be paved with a paving material that is consistent with or matches the adjacent sidewalk. Storefront assemblies (doors, display windows, bulkheads, and associated framing) should not be set back within the Shopfront openings more than 2 ft. Doors shall match the design, materials, and character of the display window framing. "Narrowline" aluminum windows are prohibited. Walls without openings shall not exceed 10 linear feet along the Primary Street frontages and 25 linear feet along Side Street frontages. Shopfront glass shall be clear without reflective glass frosting or dark tinting (less than 15%, low emissivity, solar is acceptable). Transom clerestory windows may be clear, stained glass, or frosted glass. Bulkheads shall be of a material similar or complementary to the main materials of the building or that appear heavier than adjacent walls, like ceramic tile, polished stone, or glass tile. Awnings shall not contiguously extend across the entire facade. Shopfronts with accordion-style doors/windows or other operable windows that allow the space to open to the street are encouraged. If awnings are used, models that retract are encouraged.

FRONTAGES: SHOPFRONT SIZE

		(FT)
AWNING DEPTH	(A)	4 MIN.
HEIGHT TO TOP OF TRANSOM (CLEAR)	(B)	10 MIN. / 16 MAX
HEIGHT TO BOTTOM OF AWNING/ CANOPY (CLEAR)	(C)	8 MIN. / 10 MAX.

TABLE 3.13: FRONTAGES: SHOPFRONT SIZE

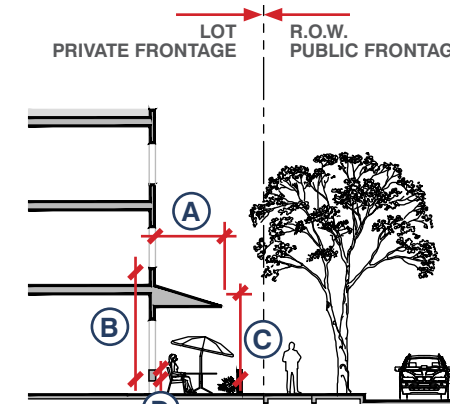

FIGURE 3.26: SHOPFRONT FRONTAGE SECTION

FRONTAGES: SHOPFRONT FRONTAGE

		(FT)
WIDTH OF STOREFRONT BAY(S)		10 MIN.
GLASS AREA % OF GROUND FLOOR WALL		SEE SEC. 3.10.1
HEIGHT OF BULKHEAD	(D)	1 MIN. / 3 MAX.

TABLE 3.14: FRONTAGES: SHOPFRONT FRONTAGE

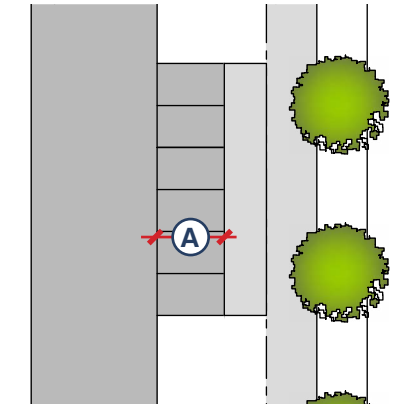

FIGURE 3.27: SHOPFRONT FRONTAGE PLAN VIEW DIAGRAM

3.9.2.6 COMMERCIAL LOBBY (MIXED USE)

In the Commercial Lobby Frontage Type, the entryway, which includes an ingress/egress door and any adjacent sidelight, transom windows or side wall is recessed from the facade face. This type is intended for retail and other commercial uses. An awning or solid roof may be added to provide shade or it will be covered from a second floor unit's balcony/deck.

Lobby entryway glass shall be clear without reflective glass frosting or dark tinting. Lobby windows may include sidelights to the left or right of the door or clerestory or transom windows (horizontal panels) between the shopfront and second floor/top of single-story parapet. The glass shall be of a character to allow light, while moderating it such as stained glass, glass block, painted glass, or frosted glass. Entryways with accordion-style doors/windows or other operable windows that allow the space to open to the street are encouraged. If awnings are used, models that retract are encouraged.

FRONTAGES: COMMERCIAL LOBBY

		(FT)
INTERIOR CEILING HEIGHT (FROM FLOOR)	Ⓐ	10 MIN.
DEPTH OF ENTRYWAY (DOOR RECESS, CLEAR)	Ⓑ	3 MIN.
WIDTH OF ENTRYWAY (BETWEEN WALLS)	Ⓒ	4 MIN.

TABLE 3.15: FRONTAGES: COMMERCIAL LOBBY

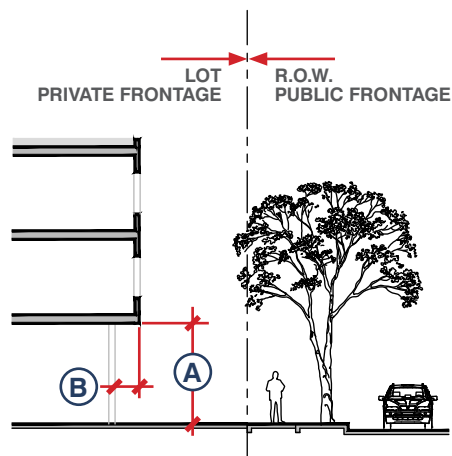

FIGURE 3.28: COMMERCIAL LOBBY FRONTAGE SECTION

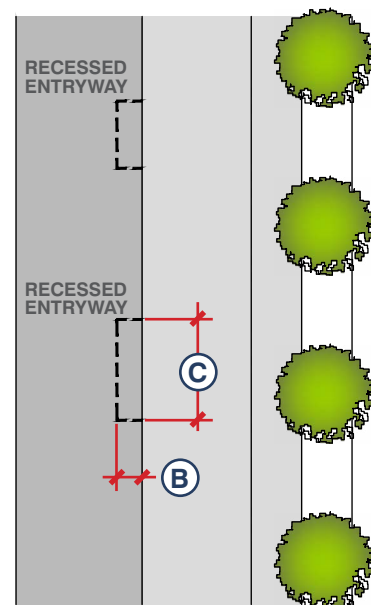

FIGURE 3.29: COMMERCIAL LOBBY FRONTAGE PLAN VIEW DIAGRAM

3.9.2.7 ARCADE (M,L, MIXED USE)

In the Arcade Frontage Type, a colonnade structurally and visually supports the building mass on the ground floor or, for one-story buildings, supports the roof. The main facade of the building is set back along the depth of the arcades. The arcade should be located at the setback line, and may step back to the second story, or may be designed to be flush with the building wall above. Arcades contain ground-floor shopfronts, making them ideal for retail or restaurant use, as the arcade shelters the pedestrian while shading the storefront glass, preventing glare that might obscure views of merchandise.

Arcades shall be combined with the Shopfront frontage type. Column spacing and colonnade detailing, including lighting, shall be consistent with the style of the building to which it is attached to. Column spacing should correspond to storefront openings. Columns shall be placed in relation to curbs so as to allow passage around and to allow for passengers of cars to disembark. Along Primary Streets, walls without openings shall not exceed 10 linear feet.

FRONTAGES: ARCADE SIZE

		(FT)
DEPTH (FACADE TO INTERIOR COLUMN FACE)	Ⓐ	8 MIN. / 16 MAX.
HEIGHT (SIDEWALK TO CEILING)	Ⓑ	12 MIN. / 16 MAX.
LENGTH ALONG FRONTAGE		TO CORRESPOND TO SHOPFRONT FRONTAGE

TABLE 3.16: FRONTAGES: ARCADE SIZE

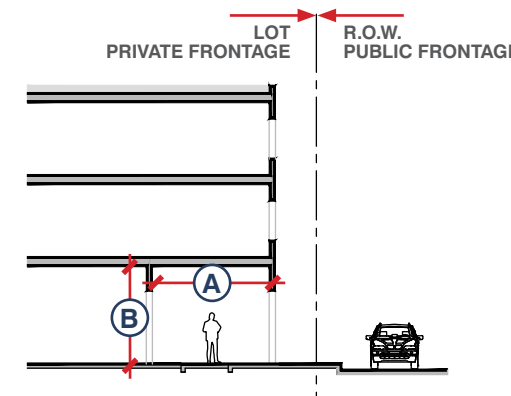

FIGURE 3.30: ARCADE FRONTAGE SECTION

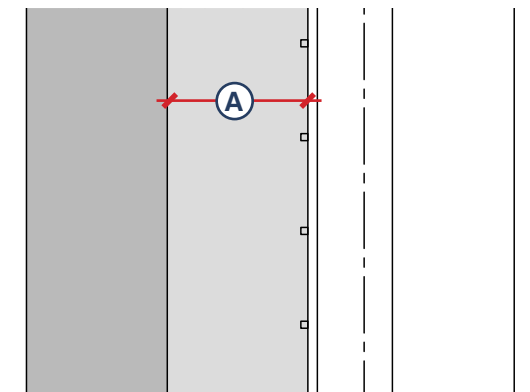

FIGURE 3.31: ARCADE FRONTAGE PLAN VIEW DIAGRAM

3.9.2.8 GALLERY (M,L, MIXED USE)

In the Gallery Frontage Type, the main facade is set back from the property line, and a covered structure, such as a colonnade or cantilevered roof, extends over the public sidewalk from the building to provide shade and shelter for pedestrians and retail activity. Railing on top of the gallery is only required if the gallery roof is accessible as a deck, in which case the materials, style, and design should be consistent with the building. Where Galleries encroach over the sidewalk in the public right-of-way, they shall require approval from Public Works pursuant to Chapter 74, Article IV of the San Fernando Municipal Code.

Galleries shall be combined with the Shopfront frontage type. Column spacing and colonnade detailing, including lighting, shall be consistent with the style of the building to which it is attached. Column spacing should correspond to storefront openings. Columns shall be placed in relation to curbs so as to allow passage around and to allow for passengers of cars to disembark. Along Primary Streets, walls without openings shall not exceed 10 linear feet.

FRONTAGES: GALLERY SIZE

	(FT)
DEPTH (FACADE TO INTERIOR COLUMN FACE)	(A) 12 MIN. / 16 MAX.
HEIGHT (SIDEWALK TO CEILING)	(B) 12 MIN. / 16 MAX.
LENGTH ALONG FRONTAGE	TO CORRESPOND TO SHOPFRONT FRONTAGE

TABLE 3.17: FRONTAGES: GALLERY SIZE

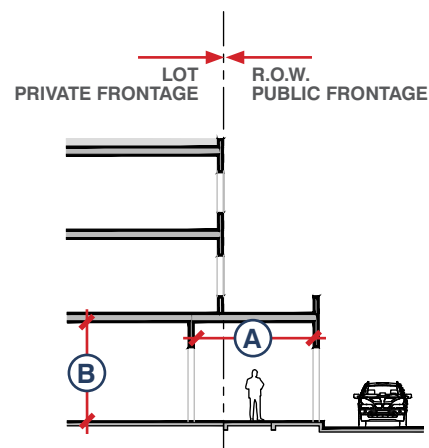

FIGURE 3.32: GALLERY FRONTAGE SECTION

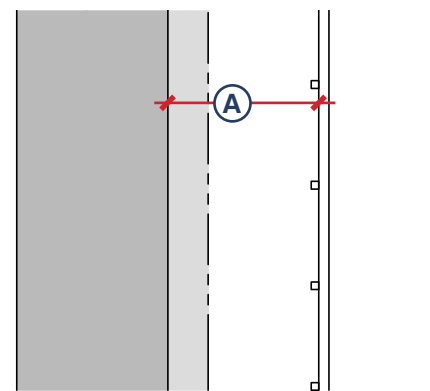

FIGURE 3.33: GALLERY FRONTAGE PLAN VIEW DIAGRAM

3.9.2.9 RESIDENTIAL GROUND FLOOR PATIO (S,M,L)

In the Residential Ground Floor Patio Frontage Type, a residential private patio extends from the ground floor residential unit. This type will be found only adjacent to a ground floor residential unit. A door to access the patio will be found linking the patio to the interior space of the unit and it may include an awning or to provide shade or be covered from a second floor unit's balcony/deck. There may be access into the patio via a gate from adjacent sidewalk or garden space.

Ground floor patio shall adhere to private open space standards found in Section 2.3.2. Walls or fencing separating the ground floor patio private open space from adjacent public open space shall adhere to standards found in Section 5.4 Walls & Fencing.

FRONTAGES: RESIDENTIAL GROUND FLOOR PATIO

	(FT)
DEPTH	(A) 6 MIN.
HEIGHT, CLEAR	(B) 8.5 MIN.

TABLE 3.18: FRONTAGES: RES. GROUND FLOOR PATIO

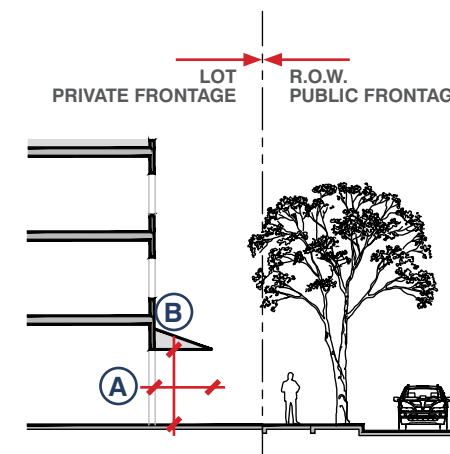

FIGURE 3.34: RESIDENTIAL GROUND FLOOR PATIO FRONTAGE SECTION

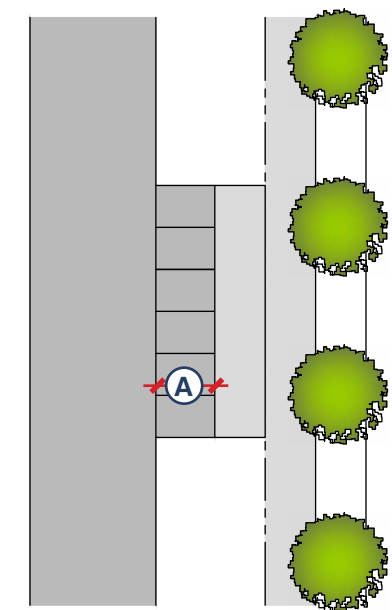

FIGURE 3.35: RESIDENTIAL GROUND FLOOR PATIO PLAN VIEW DIAGRAM

3.9.2.10 RESIDENTIAL ACCESSORY USE (M,L)

Uses at the ground floor adjacent to a residential frontage type will vary per development but may include a common-use gym, meeting space/conference room, administrative office, leasing center, indoor playroom, or other community-related uses. This frontage type is intended for residential use only. The amount of glazing at the sidewalk level will be dependent on the use within. It may include an awning to provide shade or be covered from a second floor unit’s balcony/deck.

Residential accessory uses shall allow reflective glass frosting or dark tinting due to the private nature of the accessory use. Glass shall be of a character to allow light, while moderating it such as stained glass, glass block, painted glass, or frosted glass. Accordion-style doors/windows or other operable windows that allow the space to open to the street are allowed for uses such as a gym where maximum airflow is preferred.

FRONTAGES: RESIDENTIAL ACCESSORY UNIT

		(FT)
DEPTH	Ⓐ	PER SETBACK
HEIGHT, CLEAR	Ⓑ	8 MIN.

TABLE 3.19: FRONTAGES: RES. ACCESSORY UNIT

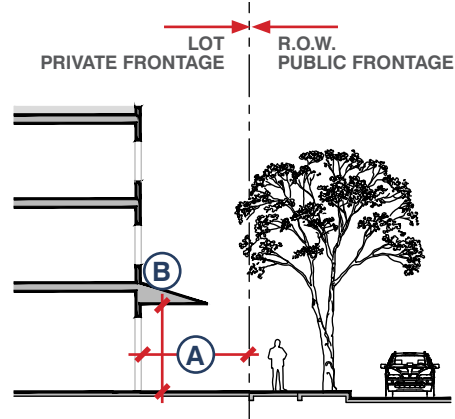

FIGURE 3.36: RESIDENTIAL ACCESSORY USE FRONTAGE SECTION

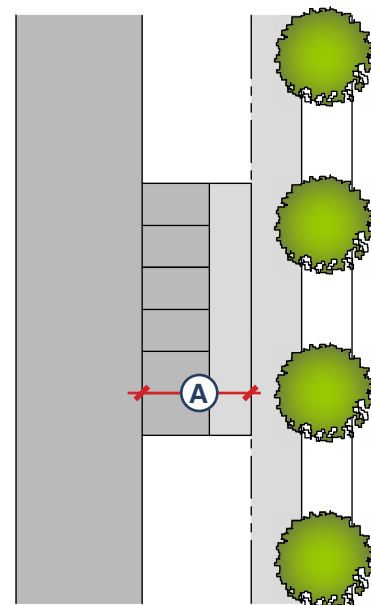

FIGURE 3.37: RESIDENTIAL ACCESSORY USE FRONTAGE PLAN VIEW DIAGRAM

3.10 ACCESSORY STRUCTURES ON RESIDENTIAL PROPERTIES

Accessory buildings and structures such as a garage, workroom, storage shed, recreation room or cabana are permitted on the same lot as the principal residential use and shall be incidental to, and not alter, the residential character of the site. (A covenant may be required to be executed and recorded to ensure the accessory use and structure is identified and maintained consistent with the City’s approval.)

The following regulations apply to all residential accessory structures except for Accessory Dwelling Units (ADUs):

1. With the exception of an attached or detached garage, an accessory structure shall not be located in front of the main building or directly between the main building and the street.
2. The total square footage of all non-parking-related accessory structures on a lot shall not exceed the lesser of these three quantities:
 - a. 500 sq. ft.,
 - b. 50 % of the ground floor of the main building, or
 - c. 50 % of the rear yard area. In R2, R3, and MU zones, up to 30 % of the rear yard area.
3. Two-story accessory structures shall have a maximum height of 25 ft. and shall consist of an accessory dwelling unit located above a garage or another qualifying accessory structure.
4. An exterior entrance to the second story of an accessory residential structure shall not project into any required minimum setback and shall be located to either face the primary dwelling unit and/or the side and/or rear property line that it is furthest away from.
5. An accessory structure smaller than 250 sq. ft. may be constructed of metal or similar material as approved by the Planning Division.
6. All accessory structures shall be properly maintained to preserve site safety and appearance. Any structure considered to be in disrepair, shall be repaired, replaced or removed from the site.

7. An accessory structure shall be maintained as a single open building and not be divided into smaller size rooms.
8. Bathrooms, kitchen plumbing or fixtures or cooking facilities within accessory buildings or accessory structures are prohibited.
9. All accessory structures shall be consistent with the prevailing architectural style of the primary structure and shall incorporate the following design components.
 - a. The existing exterior finish and treatment of the main structure on the site shall be carried onto any addition or out-building.
 - b. Buildings shall include articulation in the form of windows and doors, in the same style as the main structure.
 - c. Out-buildings shall follow the roof style of the main building when feasible. Additions shall continue existing roof lines.
10. Detached accessory structures shall be located at least 6 ft. from the main building. A breezeway may span the space between the two structures.
11. Detached accessory structures shall be located at least 3 ft. from any property line.

3.11 ACCESSORY DWELLING UNITS

Except otherwise provided in this section and Section 106-520 of the San Fernando Municipal Code, ADU's shall conform to the development standards of the underlying zone. If any provision of this section is in conflict with state law, the latter shall govern per Government Code 66316.

1. Requirements for all Accessory Dwelling Units and Junior Accessory Dwelling Units
 - a. The entrance to an ADU or Junior ADU shall meet the following standards:
 - i. Shall match the materials and color of the primary residence
 - ii. Shall not be located on the same building elevation as the main entrance of the primary residence
 - iii. Shall be located along the building side, rear, or within the interior of the property unless the Director approves an alternative configuration due to unique site conditions.
 - b. When a garage is converted to an ADU or Junior ADU and its facade is visible from a public right-of-way, the design must incorporate at least one (1) of the following elements to avoid a blank appearance:
 - i. Be covered with landscaping that covers at least 50 % of the wall
 - ii. Include openings of at least 10% of the facade with at least one (1) window which matches the material and design of the existing windows on the residence
 - c. No new roof decks are allowed for ADU's or Junior ADU's.
 - d. Exterior mechanical equipment shall have at least a 3 ft. setback from any property line.
 - e. Unless there is a fire separation requirement, no setback shall be required for an accessory dwelling unit that is within an existing structure or new accessory dwelling unit that is constructed in the same location and with the same dimensions as an existing structure.
 - f. No accessory dwelling unit may be located in a way that would prohibit access to a designated parking area or impede safe ingress and egress from a required side, rear, or front setback.
 - g. When a balcony, porch or patio is provided in conjunction with the accessory dwelling unit and is at least 7 inches above grade level, the balcony, porch or patio must be setback from the rear and side property lines a minimum of 4 ft..

3.12 UTILITIES, SERVICE AREAS & BUILDING EQUIPMENT

INTENT

- Locate and integrate utilities and service areas into building and landscape designs, in order to minimize impacts, on the pedestrian experience.

3.12.1 SERVICE AREAS, STORAGE, UTILITIES, AND EQUIPMENT

3.12.1.1 UTILITIES

In new developments, utilities shall be placed in underground or subsurface conduits unless otherwise prohibited by the City of San Fernando.

3.12.1.2 LOCATION OF SERVICE AREAS, STORAGE, UTILITIES, AND EQUIPMENT.

1. All above-ground utilities and equipment (e.g., electric and gas meters, fire sprinkler valves, backflow prevention devices, etc.), service areas (e.g. garbage collection areas, loading docks, etc.), and storage areas shall be integrated into the building and landscape design, and located to minimize impact on the pedestrian experience and neighboring properties, by following the standards below:
 - a. Utilities, equipment, service areas, storage, and non-passenger loading zones shall be located inside buildings or away from the primary building frontage, preferably along alleys, parking areas, or at the rear or side of the building, if not part of the primary frontage.
 - b. Utilities and equipment, service, storage, and non-passenger loading areas shall be consolidated within a single area. They shall not be located within minimum setback areas, within 25 ft. of open space areas, within the public right-of-way, and/or within 25 ft. of a street corner.
 - c. Backflow preventers shall be located within landscaped areas and covered with freeze protection, typically in a green color (e.g., Hex #013220). Cages should only be installed if backflow preventers are located near areas with vehicle overhangs for additional protection.
 - d. Utilities, above-ground-mounted transformers/meters, mechanical equipment, service areas, storage, and non-passenger loading zones shall be fully screened from public rights-of-way and adjacent properties. Screening shall consist of solid enclosures, lush landscaping, or architectural elements that are consistent with the building design.
2. All above-ground utilities and equipment (e.g., electric and gas meters, fire sprinkler valves, irrigation backflow prevention devices, etc.), service areas and storage areas shall be plotted and identified on project plans submitted for conceptual review.

3.12.1.3 SERVICE, STORAGE, UTILITY, AND EQUIPMENT SCREENING.

1. All service and storage areas, utilities, and equipment not housed inside buildings shall meet the following screening standards:
 - a. Screening shall be a minimum 3 inches higher than the height of the equipment to be screened.
 - b. Screening shall follow the same design, colors, and materials as the building walls to maintain visual consistency and complement the overall architectural style.
 - c. Landscape screening shall be used to mitigate the enclosed structure. The plantable space around the enclosure must be a minimum of 36 inches wide and include dense, evergreen shrubs or small trees that reach a minimum height of 4 ft. within four years of planting. A minimum spread of 2 ft. shall be required at time of planting.

3.12.1.4 LOCATION AND SCREENING OF ROOFTOP EQUIPMENT.

1. Rooftop elements including roof access, mechanical equipment, and other features needed for the function of the building, shall be located to minimize visual impact by meeting the following requirements. Mechanical equipment less than 2 ft. in height, solar panels, or wind generators are exempt from these requirements.
 - a. Roof-mounted equipment and screening of roof-mounted equipment shall be stepped back from top of parapet a minimum of 10 ft. from the parapet or roof edge.
 - b. Roof-mounted equipment that extends higher than the parapet wall shall be fully screened by an architectural screen element similar in design and color to the underlying building. Wood lattice is not permitted as a screening device. A pre-manufactured screening device that aligns with the building's architecture may be used as an alternative.
 - c. Screening must effectively block views of rooftop equipment from a point 6 ft. above ground level at the property line, the sidewalk on the opposite side of the street, or from any adjacent property and public rights-of-way.
 - d. The location, spacing, materials, and colors of down-spouts, gutters, scuppers, and other drainage components shall be incorporated into the architectural composition of the facade and roof. Downspouts shall be concealed within walls or located to harmonize with window spacing and facade composition.

3.12.2 WASTE REMOVAL

This section applies to solid waste removal areas, which include refuse, organic waste, and recycling areas not accessible to the public and used exclusively by the tenants/owners of the development site. In addition to these standards, all developments shall comply with the City of San Fernando Municipal Code Chapter 70 Solid Waste and Recyclables Collection Services. Trash areas shall be provided in accordance with Chapter 106, Article III, Division 8 and in a form approved by the Director.

However, in multi-family residential development projects where no dedicated trash enclosure is provided, all trash and recycling containers must be stored out of public view, such as behind an owner's wall or within a garage. Containers may only be placed in public view for collection purposes.

3.12.2.1 LOCATION

1. Refuse, organic waste, and recycling collection areas shall be located inside buildings or within trash enclosures placed along alleys, at the rear, or on the side of buildings. Collection areas are prohibited within any required front yard or street side yard, any required parking spaces, and required landscape and open space areas. Refuse, organic waste, and recycling containers shall not be visible from a public street, private street, or pedestrian pathway that has Primary Building Frontages.
2. In multi-building residential developments, refuse, organic waste, and recycling containers that serve only one (1) building must be located within that building to ensure residents do not need to travel to another building to dispose of waste. In mixed-use developments, commercial refuse and recycling containers should be integrated within the commercial building or placed in designated areas that are easily accessible from the commercial spaces, without requiring tenants or customers to cross to another building.
3. The location of trash enclosures shall not conflict with circulation or parking conditions on site, or adequate sight clearance for vehicular and pedestrian safety as required on Sec. 106-378 of the zoning code. A clear pathway with a minimum width of 3 ft. shall be provided for tenant access to the enclosure.
4. Refuse collection areas shall be located within the building and positioned within 250 ft. of any residential units on each floor in mixed-use developments. This placement ensures convenient access for residents while minimizing the impact on open spaces and living areas.
5. All trash areas shall be located and arranged both for convenience to residents and for convenient vehicular access and pickup. No trash enclosure shall be located within 10 ft. of any window opening into a dwelling unit, combustible walls, building openings or roof eave lines (individual unit bins are not subject to these requirements). The trash area shall remain outside of utility easements and 10 ft. away from water utility lines, in order to prevent damage to and contamination of the water line from dumpster placement.

3.12.2.2 EXTERIOR TRASH AND RECYCLING ENCLOSURES

Exterior collection areas must be within an enclosure that meets the following standards:

1. All trash and garbage collection facilities shall be either enclosed within a building or by a screening fence or wall and gate five to 6 ft. in height.
2. Recycling and refuse storage facilities for non-residential uses shall be separate from residential uses, clearly marked, located as far as possible from residential units and shall be completely screened from view from the residential portion of the development. The location and design of trash enclosures shall mitigate nuisances from odors when residential uses might be impacted. Trash areas for food service and sales uses, when occupying the same building as residential uses, shall be refrigerated to control odor.
3. Trash enclosures and refuse storage facilities shall be designed to include a concrete slab base that extends to the limits of the exterior on the sides and rear and extends beyond the service gates equal to the enclosure depth.
4. A pedestrian access and separate access for primary collection shall be provided.
5. Trash enclosures shall be constructed of materials that match the primary materials used in the principal building, ensuring consistency in design and appearance. Refer to Chapter 4: Architectural Styles.
6. Gates shall be solid metal painted to match the enclosure.
7. Concrete curbs, bollards or wheel stops shall be installed or constructed inside the enclosure to prevent bins from damaging the enclosure.
8. The proposed trash enclosure shall be sized to accommodate an organics recycling bin, as required by State Assembly Bill 1826.
9. Number and size of trash areas shall be as follows:
 - a. For residential facilities of one (1) to three (3) units: no specific number or size requirement.
 - b. For residential facilities of four (4) or more units: a common trash area shall be provided of at least 4.5 ft. by 15 ft. with an additional 5 sq. ft. of trash area for each unit over thirteen (13) (per Sec. 106-384 (3)(b)).
 - c. Trash and recyclable receptacles shall be covered with a lid and must remain closed except when loading or unloading.
10. All trash enclosures shall obtain approval for capacity, location, and design from the City's franchise waste hauler before issuance of a building permit.

3.12.3 MAIL DELIVERY

1. All projects shall meet current U.S.P.S. mailbox and delivery standards.
2. Mailbox(es) within a multifamily building shall be located within shared lobbies or designated mail rooms.
3. Mailbox(es) within a multifamily complex shall be in a centralized location and not be more than 350 ft. walking distance from the units they belong to. The location must be convenient and safe for both residents and mail carriers. The mailbox(es) must be on an accessible route with safe, well-lit pathways, with level ground with clear ground space of at least 30 by 48 inches in front of the mailboxes to allow for wheelchair access. They shall be installed where they cannot be obstructed by vehicles, equipment or debris.

3.12.4 SECURITY BARRIERS

1. Any security barriers installed on the windows or the doors of the premises shall be installed only on the interior of the building and in compliance with all City Building, Zoning, and Fire Codes.
2. Security barriers shall meet the following criteria:
 - a. Only open grill design security systems located on the inside of the building shall be permitted on elevations visible from the street.
 - b. Open grill design security systems shall be primarily transparent with not less than 75% visibility from the street.
 - c. Solid roll-down security doors are prohibited unless part of a vehicle loading bay.
 - d. Interior security gates shall be opened and fully retracted during the hours of operation.

THIS PAGE LEFT INTENTIONALLY BLANK

ARCHITECTURAL STYLES

- 4.1 OVERVIEW AND APPLICATION
- 4.2 SPANISH COLONIAL REVIVAL
- 4.3 RANCH
- 4.4 CRAFTSMAN
- 4.5 CONTEMPORARY
- 4.6 TUDOR REVIVAL
- 4.7 MISSION REVIVAL



4

4 ARCHITECTURAL STYLES

PURPOSE

- To draw from regional vernacular and established styles, the architectural styles included herein are intended to establish a strong, consistent design image and direction for the City of San Fernando. All styles reflect the desires, aspirations, and vision of the City.
- To respond to local design precedents, regional climate conditions, and local building practices and materials.
- To communicate the essential features of each style. Within each style, required design elements relating to form and massing, roofs, walls and windows, materials and colors and architectural features are outlined.
- To establish contemporary response to specific plans and current trends in each specified architectural style.

4.1 OVERVIEW AND APPLICATION







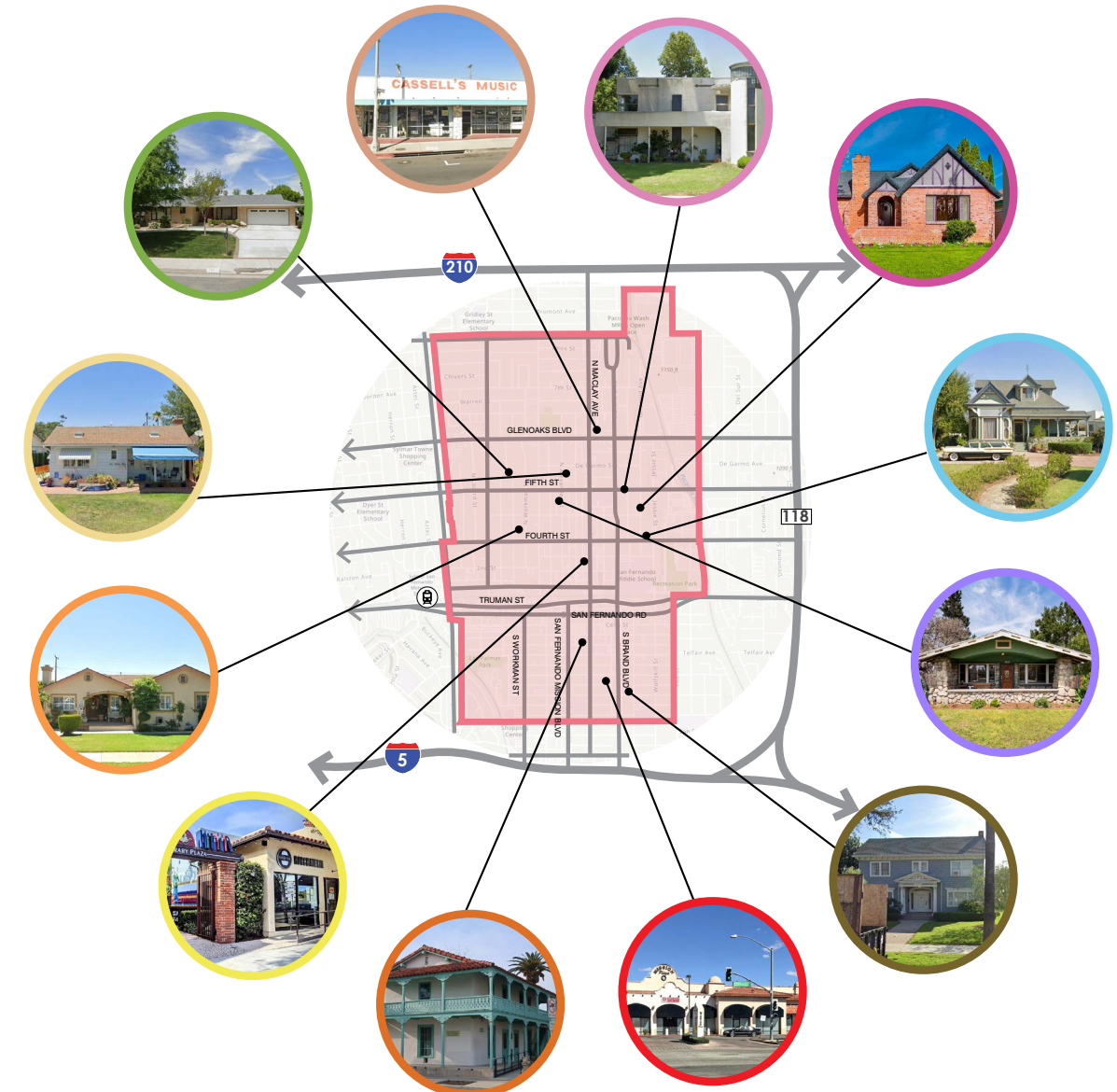





Identify existing architectural styles of distinction within the city.

4.1.1 EXISTING ARCHITECTURAL STYLES MAP

The following map identifies twelve existing architectural styles that contribute to the City’s character. Future architectural designs shall build upon these established styles, while excluding those that are no longer aligned with the community’s vision or are unlikely to be used in future development.



LEGEND

	CRAFTSMAN		QUEEN ANNE		MEDITERRANEAN REVIVAL
	MISSION REVIVAL		RANCH		TUDOR REVIVAL
	STREAMLINE MODERNE		MID-CENTURY MODERN		AMERICAN COLONIAL REVIVAL
	MONTEREY REVIVAL		MINIMAL TRADITIONAL		SPANISH COLONIAL REVIVAL

4.1.2 PROPOSED ARCHITECTURAL STYLES

The following six architectural styles have been carefully selected to guide future development in accordance with the Objective Design Standards. These styles reflect the city's desired aesthetic character, support cohesive neighborhood design, and promote architectural continuity across new construction, infill development, as well as renovations that change the architectural style of an existing building.



SPANISH COLONIAL REVIVAL



RANCH



CRAFTSMAN



CONTEMPORARY



TUDOR REVIVAL



MISSION REVIVAL

4.1.3 APPLICATION

Each style provides a clearly defined framework of required and optional architectural features in the categories of roof, walls and windows, materials and colors, and decorative accents and details, providing flexibility for creative expression while ensuring consistency with the main characteristics of each architectural style.

1

SELECT ARCHITECTURAL STYLE

2

COMPLY WITH ALL 4 CATEGORIES

The architectural styles are divided into four categories: Roof, Walls and Windows, Materials and Colors, and Decorative Accents and Details.

1. ROOF

2. WALLS AND WINDOWS

3. MATERIALS AND COLORS

4. DECORATIVE ACCENTS AND DETAILS

3

PROVIDE REQUIRED & OPTIONAL FEATURES

Each category has two (2) components: required and optional. All required features must be fulfilled, while the optional component offers a selection of features to choose from, with a minimum number of features that must be selected depending on the category.

REQUIRED: MEET ALL FEATURES

OPTIONAL: SELECT MINIMUM NUMBER OF FEATURES

4.2 SPANISH COLONIAL REVIVAL

STYLE DESCRIPTION

The Spanish Colonial Revival is an architectural style based on the details of Spanish buildings constructed in America during the Spanish colonial era. The style's growth was influenced by the Spanish-style buildings at the 1915 Panama-California Exposition in San Diego, California. Inspired by the growing interest in the vernacular architecture of Southern Spain in the 1920s, the Spanish Colonial Revival incorporates details inspired by Moorish, Byzantine, Gothic, or Renaissance architecture, as well as roof tiles common to historical construction in Mediterranean areas.

The style has features such as porches, small balconies, towers or turret bays, paneled wood doors, and prominent focal windows appearing in strong examples of the style. The character-defining features of the style include, but are not limited to smooth or sometimes moderately textured stucco exteriors, low-pitched gable and/or hip roofs with little to no eave overhang, clay roof tiles, arched windows and openings, occasional tower used as a vertical accent, courtyards, wrought iron railings for balconies and window grilles, asymmetrical façades, mix of large focal windows and smaller rectangular windows, attic vents consisting of small-diameter red clay pipes, or set behind patterned screens, paneled wood doors with elaborate surrounds, and distinctly shaped and capped chimneys.

4.2.1 ARCHITECTURAL FEATURES



4.2.2 ROOFS

REQUIRED ELEMENTS

- Low pitched roof at 4:12 to 5:12 slope
- Red clay tile, concrete-tile, or tile-profiled metal roofing. The appearance of these roof types shall emulate the traditional Spanish red clay tile roof. Common shapes include both Spanish (S-shaped) and Mission (half cylinder/ barrel tile) types
- Overhanging eaves (overall horizontal projection of a minimum of 3 inches) that face a public street with exposed rafter tails or beams
- Small, minimum of 3 inches and a maximum of 1 ft. decorative exposed rafter tails
- Simple hip or gable roof with one intersecting gable roof

OPTIONAL ELEMENTS (CHOOSE AT LEAST 2)

- Shed roof over porch
- A shed roof additive element either on the side or front facing
- Shaped parapet with coping
- Brackets or knee braces at gabled ends
- Hipped-roof towers or belvederes (square, rectangle or circular in plan)



4.2.3 WALLS & WINDOWS

REQUIRED ELEMENTS

- Stucco walls or plaster siding
- A minimum of one (1) arched window along a public-facing facade
- Multi-lite (synthetic allowed) or multi-pane configurations of windows
- Simple divisions of window mullions
- Recessed windows, minimum 2 inches deep for a at least 60% of all windows

OPTIONAL ELEMENTS (CHOOSE AT LEAST 1)

- Mix of large focal windows and smaller rectangular windows
- Minimum of 1 ft. deep walls for street or public-facing facades.
- A minimum of one (1) arched opening at entries or arcades



4.2.4 MATERIALS & COLORS

REQUIRED ELEMENTS

- Light, natural, neutral colors for exterior stucco, such as white, ivory, cream, or beige. For Spanish-style architecture with Mexican influence, wall colors may include warm, earthy tones such as terracotta, ochre, deep yellows, and creams, with vibrant accents such as bright blues, vivid pinks, reds, and greens.
- Wood elements such as rafter tails shall be painted darker and/or contrasting color that also complements the reddish-orange of the clay tiles, such as brown, dark brown, or a natural dark stain with protective finish

OPTIONAL ELEMENTS (CHOOSE AT LEAST 1)

- Wood, composite wood, fiberglass for garages
- Wrought iron, metal, composite wood, or wood for railings
- Stucco, composite wood, or wood, metal for porches
- Terra-cotta clay barrel tiles, stucco, copper, steel for faux chimneys
- Wrought iron, stone, stucco, wood, metal for handrails on stairs and ramps



THIS PAGE LEFT INTENTIONALLY BLANK

4.2.5 DECORATIVE ACCENTS & DETAILS (CHOOSE AT LEAST 6)



WINDOW GRILLES

Window grilles shall be placed on clerestory windows.



RECESSED NICHES

Recessed niches shall occur at a frequency of 1 per 200 linear feet of building perimeter.



WOOD FINISH DOORS

Wood finish doors shall occur at pedestrian and vehicular entry doors.



UNIQUELY SHAPED WINDOW

One uniquely shaped window shall be required per ground level residential unit.



DECORATIVE TILES

Decorative tiles shall occur at building entries.



CLAY/ CONCRETE TILE VENTS

Red clay or concrete tile vents shall occur at gable ends.



AWNING

Awnings shall occur at ground floor openings. Visible decorative metal supports are acceptable.



STACKED BRICKS WALL ACCENTS

Stacked brick wall accents shall occur at balconies.



WROUGHT IRON LIGHT FIXTURES

Wrought iron, painted steel or bronze light fixtures shall occur at building entrances at a minimum of 1 per 200 linear feet of building perimeter.



COURTYARD

Courtyards shall occur at building entrances or as common open spaces.



DECORATIVE METAL RAILING

Wrought iron, bronze or black painted tubular steel railings with decorative patterns shall occur at balconies.



SMALL PORCH

Small porches shall occur at building entries or outside ground level units.

4.3 RANCH

STYLE DESCRIPTION

The Ranch architectural style was wide-spread in the United States from the 1940s to the 1970s. This style is known for its single-story, ground-hugging profile. The ranch style offers easy accessibility and a seamless connection between indoor and outdoor spaces. While ranch homes vary in size and layout, they are widely appreciated for their open, functional and open floor plans. They feature large windows, sliding glass doors, use wood, brick and stucco, and have simple, clean lines with minimal ornamentation. The roofs are typically low-pitched and either gabled or hipped. They also tend to have asymmetrical plans with L- or U-shaped configurations, integrated with the landscaping or outdoor features such as patios. Attached garages are also a staple, reflecting the car-centric culture of the mid-century America.

4.3.1 ARCHITECTURAL FEATURES

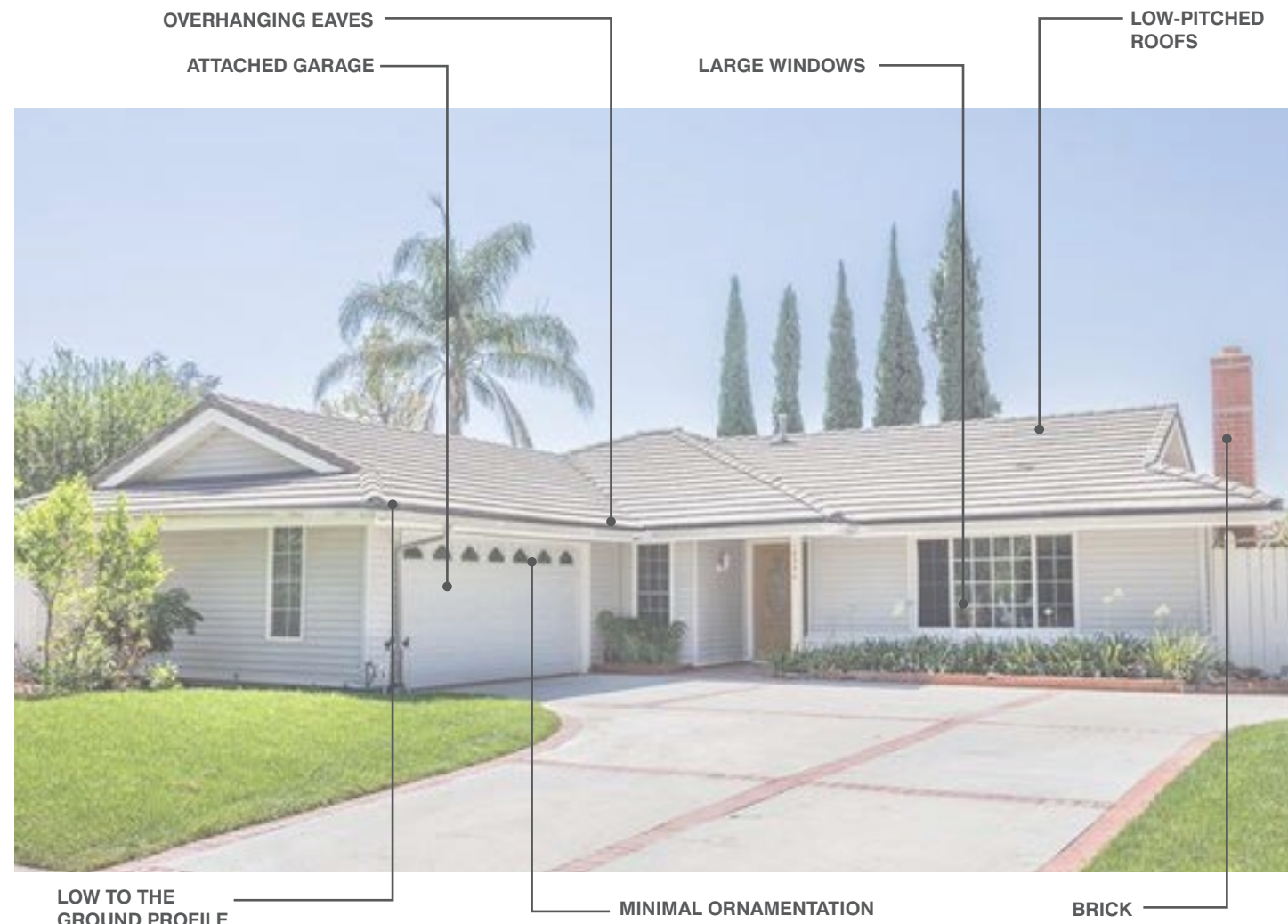

4.3.2 ROOFS

REQUIRED ELEMENTS

- Low-pitched gable, cross-gabled, shed, hip, and gable-on-hip roofs with overhanging eaves, and exposed rafters
- Roof pitch shall not exceed 4:12
- Roof pitch and materials on independent slopes and gables should be consistent
- Roofs that have eaves shall overhang building walls by no less than 18 inches

OPTIONAL ELEMENTS (CHOOSE AT LEAST 1)

- Accent roof over garage
- Accented overhangs with brackets
- Dormers
- Unique roof design treatment over garage



4.3.3 WALLS & WINDOWS

REQUIRED ELEMENTS

- Recessed, off-centered main entrance
- At least one (1) large picture window with multi-lite (synthetic allowed) or multi-pane windows in the front of the house
- Entrance doors, placed under porches, integrated into the main roofline or wide overhanging eaves

OPTIONAL ELEMENTS (CHOOSE AT LEAST 1)

- Entry porches, recessed and sheltered by an extended roof, supported by a beam and columns not to exceed 6 inches by 6 inches
- A minimum of three (3) multiple paned windows per 100 linear feet per floor
- Bay, hexagon, or diamond-divided windows
- Paneled garage doors



4.3.4 MATERIALS & COLORS

REQUIRED ELEMENTS

- Use of natural materials like wood, brick, and stone
- Window materials shall be consistent throughout the house
- Stucco, wood siding, or hardie-board of exterior walls

OPTIONAL ELEMENTS (CHOOSE AT LEAST 1)

- Asphalt roof shingles, slate or faux-slate
- Where stucco is used on the primary exterior wall, horizontal siding shall be used beneath the sloped area of the roof as an exterior wall accent.
- Wood siding shall including board-and-batten, lap, or tongue-and-groove. Siding and cladding material shall be mitered. Exposed siding dimensions shall be between 5" and 12"



4.3.5 DECORATIVE ACCENTS & DETAILS (CHOOSE AT LEAST 3)



INTERIOR COURTYARDS

Central, open-air space, often enclosed or semi-enclosed by the homes' wings



HORIZONTAL FENESTRATION

Long, low, horizontally oriented windows that emphasize the home's wide, grounded profile



DIAMOND-SHAPED ACCENT WINDOWS

Small, decorative windows that add visual interest to a horizontal facade and serve as focal points



DOVECOTE

Small, decorative structure designed to house doves or pigeons



VENEER BASE

A stone or brick veneer base that is a minimum of 40 inches in height shall be required for at least 60 % of the elevation facing a public open space or street



PEDIMENTS

Modest, triangular or arched gable-like elements placed above doors, windows, or entryways

4.4 CRAFTSMAN

STYLE DESCRIPTION

The Craftsman style originated in Southern California and was most commonly applied to bungalow-scale residential homes, emphasizing hand craftsmanship, natural materials, and human-scaled proportions. The contemporary Craftsman architectural style interprets traditional Craftsman forms and materials while accommodating modern construction methods and uses. Identifiable features include low-pitched gabled roofs, sometimes with exposed rafters, and partial or full balconies supported by tapered square columns. Additional character-defining elements include deep roof overhangs with decorative brackets, prominent front porches, horizontal massing, and the use of wood siding, shingles, stone, or brick to articulate building bases and entries, creating a warm and grounded architectural expression.

4.4.1 ARCHITECTURAL FEATURES



4.4.2 ROOFS

REQUIRED ELEMENTS

- Low to medium-pitched (between 4:12 and 6:12 slope)
- Front and/or side facing gables
- Variation in heights and/or planes
- Asphalt shingle, or synthetic slate shingles
- Multiple roof planes
- Overhanging eaves (minimum 24 inches along primary elevation) with exposed rafter tails or beams
- Brackets or knee braces at gabled ends
- Decorative lattice vents
- Dormers



4.4.3 WALLS & WINDOWS

REQUIRED ELEMENTS

- Utilize board and batten siding, shingles or corrugated panels to give texture and variation to exterior walls
- Siding materials shall be wood, composite wood, steel, or fiber cement
- Minimum 3 inches and maximum 5 inches molding around window and door openings
- Double hung windows with muntins or casement windows with muntins
- Windows shall have mullion or divided lites
- Window and door trim color shall contrast with color of walls

OPTIONAL ELEMENTS (CHOOSE AT LEAST 1)

- Wide solid wood entry doors with divided lites
- Square and buttressed posts

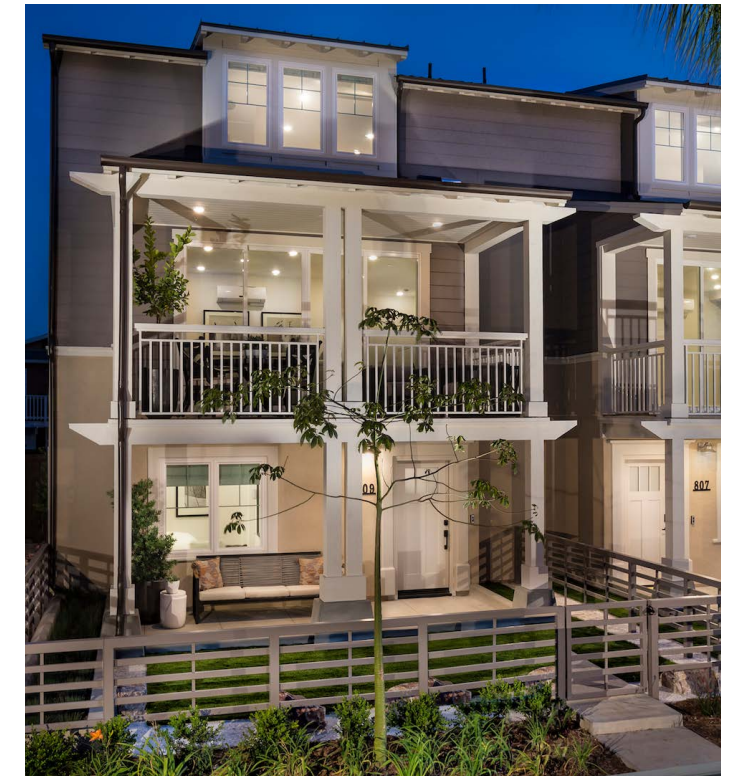

4.4.4 MATERIALS & COLORS

REQUIRED ELEMENTS

- Autumn palette which includes warm, muted hues inspired by fall foliage, harvest, and natural seasonal elements. Hues can range in oranges, rich reds, golden yellows, warm browns, olive greens, soft rusts.
- Earth tones, inspired by natural elements including soil, rocks, clay, sand, and vegetation, typically muted, warm, and neutral in appearance.
- Wood or stucco

OPTIONAL ELEMENTS (Select at least 1)

- Smooth river stone looking veneer at base min. 3 ft. from ground
- Stone or brick used for chimney bases, porch piers or wall accents



4.4.5 DECORATIVE ACCENTS & DETAILS (CHOOSE AT LEAST 4)



FRONT PORCH

Front porch(es) having a minimum width of 12 ft. and simple posts shall occur at building entrances or outside ground level units.



DECORATIVE VENEER ACCENTS

Symmetrical decorative stone or brick at base of columns flanking any building entrance shall reach a minimum of 40 inches in height



TAPERED POSTS

Tapered columns shall occur at building entrances.



DEEP OVERHANGS

Overhangs shall occur along linear frontage of building roof and shall have a minimum projection of 24 inches.



MULTI-PANE WINDOWS

Multi-pane windows shall occur around facades



EXPOSED BEAMS/RAFTER TAILS

Exposed beams/ rafter tails shall occur at a minimum 30% of second floor or above window openings.

4.5 CONTEMPORARY

STYLE DESCRIPTION

Contemporary is the term used for architecture of the 21st century. Unlike some other architectural periods, Contemporary isn't a movement, but a style reflecting the trends of the time a home is built.

While this style doesn't represent any particular age, past movements can inspire Contemporary design. Moreover, assorted elements from previous architectural styles—none of which will dominate more than another—often influence Contemporary homes. This style relies on fewer classical building ideas.

4.5.1 ARCHITECTURAL FEATURES



4.5.2 ROOFS

REQUIRED ELEMENTS

- A flat roof shall be provided and shall serve as either the primary roof or as a connecting roof plane linking to an accent roof form selected from the list below.

OPTIONAL ELEMENTS (CHOOSE AT LEAST 1)

- Saltbox roof
- Shed roof
- Modern gable
- Curved roof
- Flat roof



4.5.3 WALLS & WINDOWS

REQUIRED ELEMENTS

- Expansive glass panels to create opportunities for natural light
- Clean, straight or curved wall lines with a lack of fuss and ornament
- Narrow, black or white window frames

OPTIONAL ELEMENTS (CHOOSE AT LEAST 1)

- Floor to ceiling glass, clerestory windows, or skylights
- Facade walls can feature varied volumes, slanted walls, and irregular shapes for visual interest



4.5.4 MATERIALS & COLORS

REQUIRED ELEMENTS

- Raw and natural materials like wood, concrete, metal, and glass
- Use of sustainable wood and reclaimed existing materials for building
- Color accent panels

OPTIONAL ELEMENTS (CHOOSE AT LEAST 3)

- Stone
- Tile
- Brick
- Metal panels
- Stucco
- Wood Panels
- Use of traditional materials in innovative ways

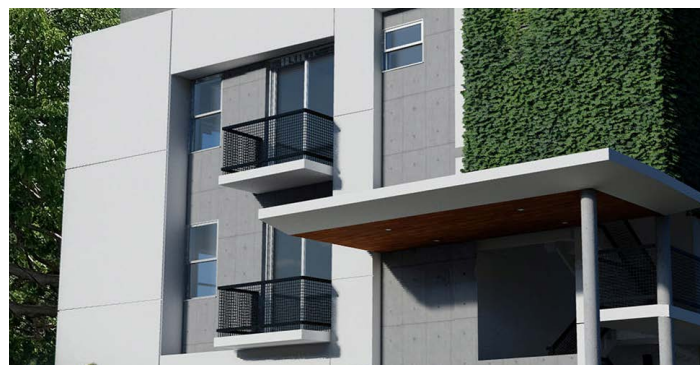
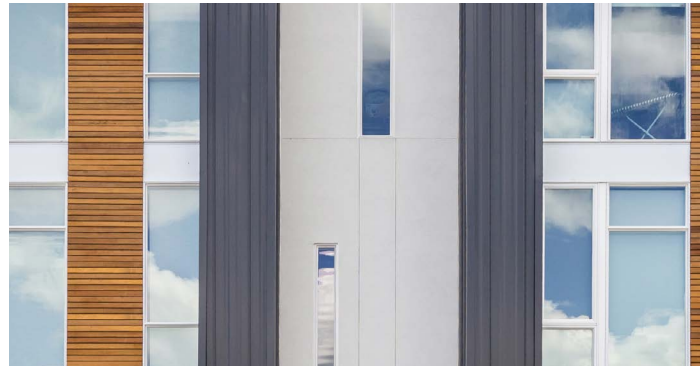

4.5.5 DECORATIVE ACCENTS & DETAILS (CHOOSE AT LEAST 3)



ARCHITECTURAL FACADE JOINTS

Use of wall screen channel joint or facade joints that align with facade elements in a vertical and/or horizontal direction.



WINDOWS WITHOUT MULLIONS

Occur for all windows located along all street or pedestrian orientated frontages.



FLUSH EAVES

Occur along all street facing wall elevations.



METAL AWNINGS

Awnings shall occur at ground floor openings, extending a minimum of 36 inches.



ROOF DECK TRELLIS

A minimum of one (1) structure shall occur at roof deck level. Only applicable if roof deck is provided on building unit.



METAL & GLASS LIGHT FIXTURES

Metal and glass light fixtures shall occur at building entrances at a minimum of one (1) per 200 linear feet of building perimeter.

4.6 TUDOR REVIVAL

STYLE DESCRIPTION

The Tudor Revival architectural style, prevalent from 1910 to 1940, is inspired by the Tudor period in England, ranging from 1485 to 1603. It combines late medieval design with early Renaissance influences. Birtthed in the United States during the early 20th century, this style became popular for its distinctive character and strong connection to traditional European craftsmanship.

Often seen in suburban neighborhoods and estate homes, Tudor Revival architecture is distinguished by its steeply pitched gable roofs, decorative half-timbering with stucco or masonry infill, and tall, elaborate chimneys. Windows are typically narrow and grouped, featuring multi-pane or leaded glass. Other key features include arched doorways, prominent cross gables, and the use of brick, stone, or wood detailing in order to create visual texture. This style shall be limited to only one (1) and two (2) story structures.

4.6.1 ARCHITECTURAL FEATURES



4.6.2 ROOFS

REQUIRED ELEMENTS

- At least one (1) roof form with steeply pitched roofs (between 10:12 and 16:12 or even steeper), gable or hipped with heavy shingles
- Shallow eaves
- Intersecting cross-gables
- Slate or composite roofing

OPTIONAL ELEMENTS (CHOOSE AT LEAST 1)

- Side-gabled roof
- Prominent front gable
- Enlarged faux chimney decorated with stonework
- Dormers
- Attic windows



4.6.3 WALLS & WINDOWS

REQUIRED ELEMENTS

- Tall narrow windows, casement style with multiple lites
- Arched entries, which can be recessed under a small gable or portico of a minimum width of 4 ft. and a minimum depth of 2 ft.

OPTIONAL ELEMENTS (CHOOSE AT LEAST 1)

- Windows usually in multiple groups
- Pointed Tudor arch over doorways and gates
- Stained glass windows
- Shutters

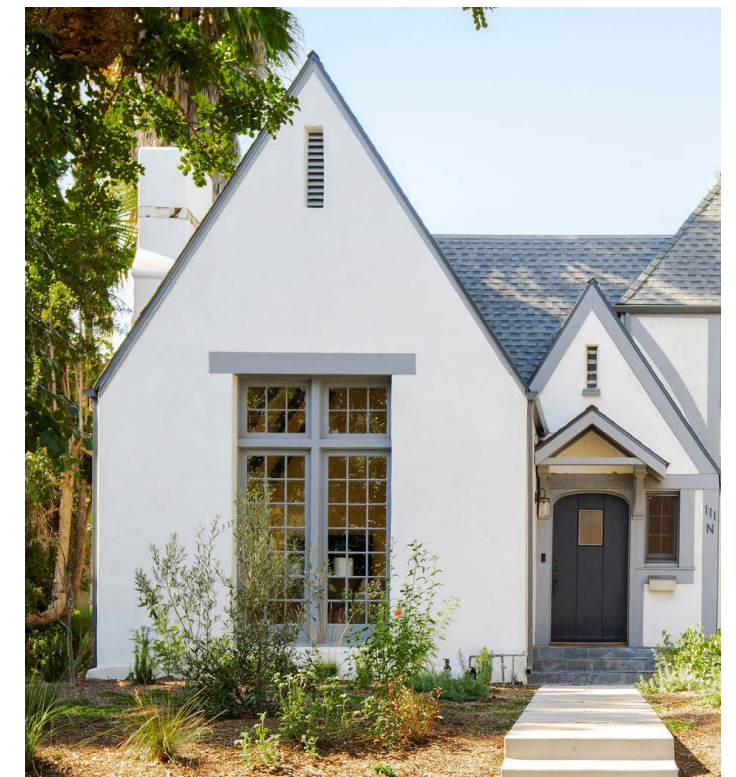

4.6.4 MATERIALS & COLORS

REQUIRED ELEMENTS

- Half-timbering for decorative purposes, often using false wooden beams and panels that create a textured, half-timbered appearance on the upper stories, with the spaces between the timbers filled with stucco, brick, or stone
- Textured exterior walls with a mix of materials
- Stone should never be painted

OPTIONAL ELEMENTS (CHOOSE AT LEAST 2)

- Masonry veneering of brick or stone (usually granite), covering the ground floor with stucco and detail above
- Roughcast stucco in the half-timbered gable
- Bold contrasting natural colors with lighter colors for the body and darker for the trims, with deep reds or greens as accents



4.6.5 DECORATIVE ACCENTS & DETAILS (CHOOSE AT LEAST 3)



ELABORATE LARGE CHIMNEYS

Large, prominent faux chimneys, sometimes with decorative chimney pots



CHIMNEY POTS

Decorative extensions placed atop tall, often clustered brick chimneys. They serve a functional and aesthetic purpose.



BAY AND ORIEL WINDOWS

Projecting windows that add depth, light and visual interest to the facade



ASYMMETRICAL DESIGN

Asymmetrical floor plan with multiple, varied gables and a picturesque, irregular composition



QUOINS

Typically made of stone or contrasting brick, quoins are cornerstones that visually reinforce the edges of a building



DECORATIVE POINTED WINDOW

A decorative window in a pointed form which uses stained glass

4.7 MISSION REVIVAL

STYLE DESCRIPTION

Mission Revival architecture is a style inspired by the Spanish missions that were established in California during the 18th and early 19th centuries. The style became popular between 1890 and 1920, and was one of the first architectural movements to draw from California's colonial heritage, blending Spanish, Mexican, and Native American influences into a uniquely regional style. Often found in civic buildings, train stations, schools, and homes throughout California and the Southwest, the style laid the foundation for later revival styles and remains a distinct and historically significant part of American architectural history.

Some of the key features include red clay tile roofs, smooth stucco walls, and wide, overhanging eaves. Arched openings, often seen in windows, doors, and arcades, are a signature element, along with bell towers, quatrefoil windows, and decorative vents that resemble historic missions.

4.7.1 ARCHITECTURAL FEATURES



4.7.2 ROOFS

REQUIRED ELEMENTS

- Raised gable with curved parapet, flat roofs with parapets, or low-pitched gabled roofs (between 4:12 to 6:12) with broad, overhanging eaves ranging from 18 to 24 inches
- Wooden roof beams or rafter tails exposed beneath eaves
- Plain flat plaster or sheet metal caps on parapet walls

OPTIONAL ELEMENTS (CHOOSE AT LEAST 1)

- Red clay tile, concrete-tile, or tile-profiled metal roofing. Both Spanish (S-shaped) and Mission (half cylinder/ barrel tile) types are acceptable.
- Bell-shaped forms, especially at the front facade



4.7.3 WALLS & WINDOWS

REQUIRED ELEMENTS

- Windows and doors recessed a minimum of 4 inches to emphasize mass and depth
- Front doors are a minimum of 42 inches wide for non-residential uses

OPTIONAL ELEMENTS (CHOOSE AT LEAST 1)

- Recessed balconies with flat or round arch openings and solid balustrades covered with cement plaster
- Open balconies over porches or loggias with flat roofs with solid balustrade covered with cement plaster
- Decorative buttresses
- Awnings



4.7.4 MATERIALS & COLORS

REQUIRED ELEMENTS

- Plain, white or light-colored stucco

OPTIONAL ELEMENTS (CHOOSE AT LEAST 1)

- Timberwork, wood framing, balustrades, and wood decorative ceilings
- Wrought iron as a decorative feature for railings, window grilles, gates, and light fixtures with a black or rusted finish
- Stone used as an accent decorative feature, providing contrast to stucco surfaces
- Decorative tiles to add a burst of color or patterns to walls or floors.
- Sand-finished cement plaster on balcony, porch or arcade ceilings

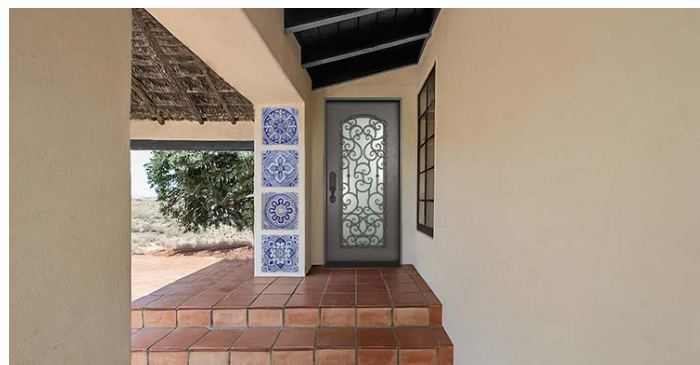

4.7.5 DECORATIVE ACCENTS & DETAILS (CHOOSE AT LEAST 2)



ARCADES

Use of arcaded walkways (row of arches supported by columns or piers)



BELL TOWERS

Central raised element



ARCHED OPENINGS

Round- arched doors and windows

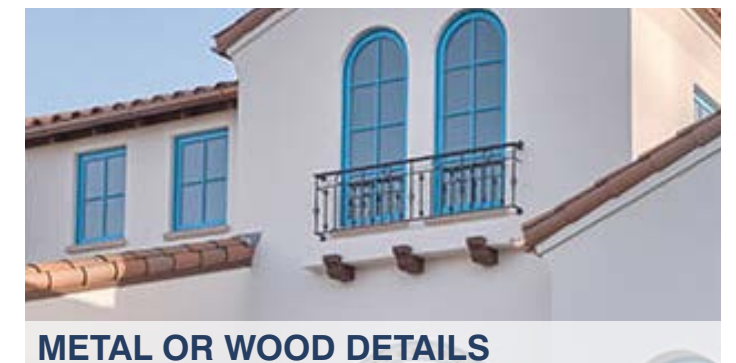

METAL OR WOOD DETAILS

These can be used for staircases, balconies, railings, or other decorative elements like gates and window guards. Metal can be wrought iron, bronze, or black painted tubular steel.



QUATREFOIL WINDOWS

Cement plaster or cast surround around quatrefoil windows



DOMES

A rounded vault forming the roof of a structure, typically with a circular base

LANDSCAPE

- 5.1 LANDSCAPE MATERIALS & VEGETATION
- 5.2 HARDSCAPE
- 5.3 WALLS & FENCING
- 5.4 LANDSCAPE LIGHTING
- 5.5 SITE FURNISHINGS



5

PURPOSE

- Emphasize landscaping as a fundamental design component, retaining mature landscaping to the extent appropriate, to reinforce a sense of the natural environment and to maintain an established appearance.
- Establish landscape clearances and other design elements to buffer residential units to the extent possible from the impacts of abutting roadway or different intensities of land uses.
- Utilize landscape design to create character and identity, enhance the appearance and function of outdoor spaces, encourage pedestrian activity, promote social interaction, enhance or integrate new natural systems, add shade to the urban environment and provide stormwater management.
- Promote sustainability goals and incorporate solutions appropriate to the climate, region and local conditions.

5.1 LANDSCAPE MATERIALS & VEGETATION

INTENT

- Provide aesthetically pleasing, low-maintenance landscapes and plantings that enhance residential buildings and outdoor private and public spaces.
- Use landscaping to frame and or enhance public spaces and create unique areas positioned for active or passive activities.

In addition to this chapter, all new or rehabilitated development shall adhere to Division 4 of Chapter 106, Article III of the San Fernando Municipal Code for the latest requirements for landscaping and screening standards.

5.1.1 LANDSCAPED AREA

1. A minimum of 20% of the lot area not comprised of buildings or required vehicular access and parking areas shall be comprised of pervious surfaces such as landscaping, gravel, rocks, or other similar pervious materials.
2. A minimum of 50% of all street-facing yard areas between the principal dwelling unit and the public or private street curb, shall be maintained as a landscaped area. Hardscape areas containing impervious surfaces shall only be used for the purpose of pedestrian and vehicular access, and paved patios and decks.
3. No more than 50% of the required landscaped areas may consist of decorative features such as boulders, river and lava rock, fountains, ponds, rock riverbeds, pedestrian bridges, arbors and pergolas with a maximum height of 9 ft.
4. Mulch may be used as an integral part of required landscaped areas.
5. The following standards shall apply to multi-family residential properties with surface parking lots:
 - a. A minimum 5 ft. landscape buffer strip shall be provided between a parking lot and public right-of-way and shall be maintained with a permanent automatic irrigation system.
 - b. Parking lot canopy trees shall be provided at the ratio of one (1) tree for every four (4) parking spaces.
6. No vehicle shall be parked in a required landscape area.

5.1.2 SOIL DEPTH

Planting in above grade planters or podium landscaped areas shall have a minimum topsoil depth of 12 inches for ground cover, 24 inches for shrubs, and 36 inches for trees.

5.1.3 SHRUBS, HEDGES, & GROUNDCOVER

5.1.3.1 GENERAL LANDSCAPE AREA

1. Plants on the Cal-IPC invasive plant inventory are prohibited.
2. Shrubs shall be a minimum size of five (5) gallons. When planted to serve as a hedge or screen, shrubs shall be planted with 2 ft. or 4 ft. of spacing, depending on the plant species.
3. Ground cover shall be generally spaced at a maximum of 6-8 inches on center. When used as ground cover, minimum one-gallon sized shrubs may be planted 10 to 24 inches on center.
4. If hedges, shrubs, and similar vegetation are maintained at the property line and are of sufficient density to block vision, they shall comply with the height limit for fences and walls within the required front, rear, and side yard setbacks, as well as with sight clearance triangle requirements.

5.1.3.2 TURF AND ARTIFICIAL TURF

1. Artificial plants and artificial turf are prohibited.
2. Natural turf areas shall be a minimum 10 ft. diameter, or 10 ft. width. Use of turf shall be in compliance with the California Model Water Efficient Landscape Ordinance (MWELO).

5.1.3.3 NON-PLANT MATERIALS, SOIL, AND MULCH

1. Crushed rock, mulch, pebbles, stones, and similar non-plant materials, where no plant material is present, shall be allowed up to 8% of the total required landscaping area.
2. Landscaped areas where plant material other than turf is present shall be top-dressed with 3-inch shredded mulch or 2-inch crushed rock, mulch, pebbles or stones to avoid exposed bare soil.
3. 3-inch minimum depth bark mulch must be confined to areas underneath shrubs and trees and is not a substitute for groundcover plants.

5.1.4 TREES

5.1.4.1 GENERAL LANDSCAPE AREA

1. All tree planting within a street facing setback shall be a canopy tree in conformance with the City of San Fernando Urban Forest Management Plan or as approved by the Community Development Director installed at a minimum 24-inch box size and a maximum distance of 30 ft. on center.
2. A minimum distance of fifteen (15) ft. is required between the center of trees to street light standards, water meters, back-flow prevention systems, sewer cleanouts and fire hydrants.
3. New and replacement tree species shall be in conformance with the City of San Fernando Urban Forest Management Plan or as approved by the Community Development Director.
4. Trees where excessive flower and fruit drop are considered a nuisance and damage/harm for both the surface they fall upon or walkway users must be avoided within 6 ft. of pedestrian walkways.
5. Evergreen trees must be used to soften the appearance of blank walls and provide visual screening but shall not be a replacement for enhanced architecture.
6. Street trees shall be required and must be an approved street tree from the City of San Fernando's Urban Forest Management Plan and approved by the Public Works Director.
7. Street Trees shall be planted at 25 ft. on-center (O.C.) maximum, or for larger trees, at a distance on-center appropriate for healthy growth based on it's expected mature width.
8. Street trees shall be installed using root barriers per City tree planting details.
9. Trees shall be planted between right-of-way street trees and the façade of the building to compliment or soften the impact of the architecture. They shall be planted at 30 ft. O.C. maximum.

5.1.4.2 SURFACE PARKING AREA

1. A minimum 5 ft. planting width is required where tree planter islands occur between parking stalls.
2. For residential parking, a canopy tree is required for every six (6) stalls of side-by-side (contiguous) parking spaces.
3. For mixed-use parking, a canopy tree is required for every seven (7) stalls of side-by-side (contiguous) parking spaces.

5.1.4.3 TREE PROTECTION

1. Newly planted trees shall be supported with double stakes and/or guy wires or approved equivalent City standard.
2. Trees planted within 10 ft. of a street, sidewalk, paved trail or walkway shall be deeply-rooted species or shall be separated from paved surfaces by a root barrier to prevent physical damage to public improvements.
3. Based on the recommendations of a qualified arborist’s report, existing trees to be preserved on site shall be appropriately protected during construction and incorporated into the overall landscape design of the development.

5.1.5 PRIVACY AND SCREENING

Landscape screening shall obscure direct sight lines into dwelling units and restricted open space areas from communal areas such as parking areas, common mailboxes, and pedestrian walkways. Landscape screening may be combined with walls, fencing, and/or trellises to screen views.

1. Landscape screening shall fit within associated planting areas and canopy sizes must not overlap with a building, walls, foundations or eaves.
2. Landscape screening shall use non-invasive evergreen trees, shrubs, and/or vines located and sized to buffer views. Deciduous species, perennials and grasses or grass-like plants are not permitted for privacy screening.
3. Landscape screening and vegetation shall use the following minimum container sizes at the time of planting (table right):

SCREENING LANDSCAPE PLANT SIZES

	SIZE (MIN.)
TREES	24-inch box.
SHRUBS	5 gal.
VINES	5 gal.

TABLE 5.1: MINIMUM CONTAINER SIZES FOR SCREENING LANDSCAPE PLANT SIZE

5.1.6 RESIDENTIAL BUFFERING

1. Buildings with residential ground-floor uses shall have a minimum of one (1) tree per building frontage width divided by 20 ft. Trees located in the adjacent right-of-way may count toward this minimum. Private entrance drive/street frontages are excluded. Trees may be staggered or in an aligned on-center spacing to comply with standard.
2. Multi-family and residential mixed-use developments abutting R-1 zoned properties shall provide a minimum 10 ft. wide landscape buffer along the entire length of the shared property line. The buffer shall include a solid masonry wall with a 6 ft. height, except within a street-facing setback where solid walls are not permitted. Also see Division 7 of Article III of Chapter 106 pertaining to walls and fences.

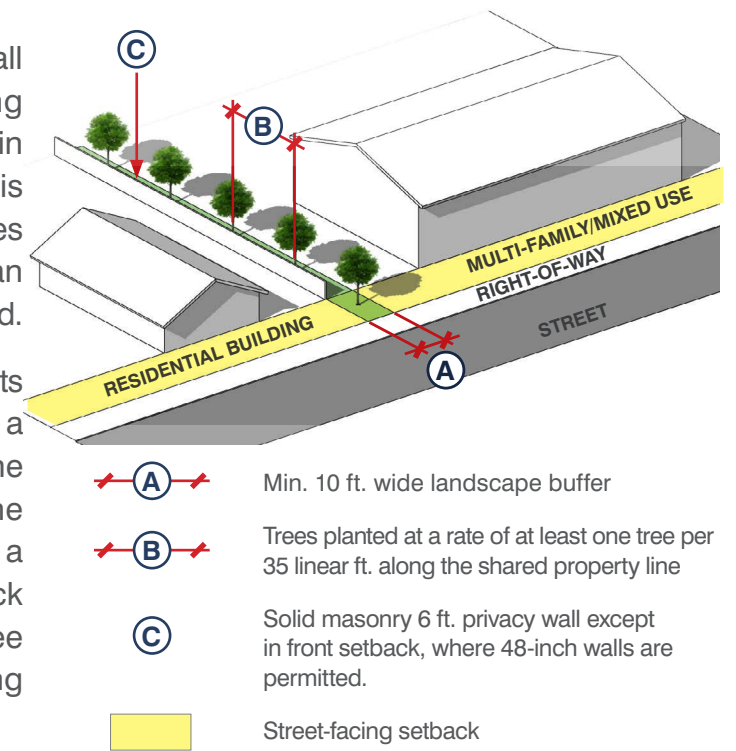

FIGURE 5.1: RESIDENTIAL BUFFERING DIAGRAM

3. For multi-family and residential mixed-use developments, a minimum 5 ft. wide landscape buffer shall be provided along the entire length of the shared property line between driveways or access aisles and abutting properties with screening trees planted at 25 ft. on-center (O.C.) maximum.
4. Whenever a mixed-use zoned lot shares a side or rear property line with a residentially zoned lot, and non-residential uses are located within 15 ft. of that side or rear property line, a 6 ft. tall solid masonry wall shall be provided, along or adjacent to all such side and rear lot lines. The wall shall conform to the height regulations applicable to front yard areas of the residentially zoned lot having the common lot line. A landscape buffer shall also be provided along the shared lot lines.

5.1.7 DROUGHT TOLERANT & NATIVE PLANT SPECIES

A minimum of 50% of non-turf landscaped areas shall be planted with drought-tolerant or native plant material. Non-native plant material will be accepted if there is no available native or drought tolerant species to support the design intent.

Plant materials shall be appropriate as identified by Water Use Classification of Landscape Species (WUCOLS) for Region 3 (South Coastal). Refer to latest WUCOLS recommendations from California Center for Urban Horticulture WUCOLS website <<https://ccuh.ucdavis.edu/wucols>>.

5.1.8 PROTECTION FROM ENCROACHMENT

Landscaping shall be protected from vehicular and pedestrian encroachment by raised planting surfaces, providing appropriately planned walkways, the use of curbs, and installing hedges to direct the flow of pedestrian traffic.

At parking stall, one (1) wheel stop per stall must be provided if a raised planter curb is not present to prevent car from damaging adjacent tree trunks or vegetation adjacent to car parks.

5.1.9 INTERFERENCE WITH UTILITIES

1. All service areas, storage areas and utility and equipment locations shall be coordinated between landscape architect and civil engineer.
2. Plant materials shall be placed so that they do not interfere with the lighting of the premises or restrict access to emergency apparatus such as fire hydrants or fire alarm boxes.
3. Trees or large shrubs shall not be planted under overhead lines or over underground utilities if their growth might interfere with such public utilities.
4. Plant material setbacks from utilities shall conform to utility company requirements.

5.1.10 SAFETY

Landscape planting must be designed to contribute to crime prevention. Shrubs that have the potential of creating hiding places shall not be placed in areas of pedestrian movement, such as along walkways and building entrances.

1. All shrubs and hedges shall not exceed three (3) ft. in height within the front and street side setback areas and thinned out at maturity. All trees should be cut so that no branches or leaves hang lower than 10 ft. from the finish surface/ground plane.

5.1.11 SITE OBSTRUCTIONS

Trees planted in a parkway, between curbs and sidewalk, shall have a clear vision triangle utilizing 30 ft. tangents at the outside line at intersection or driveway condition.

5.1.12 LANDSCAPE MAINTENANCE STANDARDS

The following landscape maintenance standards are required for all landscaped i

1. All landscaping shall be permanently maintained in a healthy and thriving condition at all times, in compliance with the approved landscape design plan.
2. Lawn and ground cover shall be trimmed or mowed regularly. All planting areas shall be kept free of weeds and debris.
3. All plantings shall be kept in a healthy and growing condition. Fertilization, cultivation, and tree pruning shall be a part of regular maintenance. Good horticultural practices shall be followed in all instances.
4. Stakes and ties on trees shall be checked regularly for correct functions. Ties shall be adjusted to avoid creating abrasions or girdling on trunks or branches.

Any person, firm or corporation, whether as principal, agent, employee or otherwise, violating any provisions of these landscape standards or failing to comply with any order or regulation made hereunder, shall be subject to the penalties set forth in Chapter 1 Article III of the San Fernando Municipal Code.

5.2 HARDSCAPE

INTENT

- Thoughtful selection and application of ground-plane materials to manage the flow of people, vehicles, and surface runoffs thereby optimizing the functionality and usability of outdoor spaces.

5.2.1 LOCATION

- For multi-family and residential mixed-use developments, primary entries to buildings shall provide decorative paving that contrasts in color and texture with the adjacent walkway paving to accentuate the entrances.
- Asphalt and standard concrete should be used only in areas of high traffic volume and service areas unseen by the average resident or visitor.
- All pedestrian-use pavement shall be ADA compliant.

5.2.2 APPEARANCE & MATERIALS

- Hardscape materials shall be constructed of firm and slip-resistant materials, see table.
- No stained or stamped concrete shall be used in any area as non-integral colored concrete quickly fades and stamped patterns become unsightly and unrecognizable over time.
- Integral color concrete shall be non-fading pigment thoroughly mixed into the full concrete depth; no top-layer surfacing color mixture is allowed.

ORDER OF PREFERRED PAVING OPTIONS

VEHICULAR	PEDESTRIAN
1. CONCRETE PAVERS ¹	1. CLAY OR CONCRETE PAVERS ¹
2. INTEGRAL COLORED CONCRETE ²	2. CONCRETE WITH AGGREGATE
3. ASPHALT	3. INTEGRAL COLORED CONCRETE ²
	4. STANDARD CONCRETE (NATURAL GRAY)

¹ Permeable is preferred where applicable.

² Using Scofield, Davis Color or City Approved Equivalent.

TABLE 5.2: ORDER OF PREFERRED PAVING OPTIONS

5.2.3 WATER MANAGEMENT AND DIVERSION

- Hardscape surfaces shall be sloped to drain water adequately per latest California Building Code 24 standards.
- Paved surfaces where water accumulates is not allowed.
- Grates and drains shall be placed within the hardscape infrastructure to remove water from the surface and channel it to the local stormwater catchment system such as bio-retention, swales, etc.

5.3 WALLS & FENCING

INTENT

- Design walls and fences to include durable materials, be aesthetically appealing, and not create a monolithic barrier along street frontages. The design of walls and fences, and the materials used shall be consistent with the overall development's design.

5.3.1 OWNERSHIP AND RESPONSIBILITY

All walls shall be placed on privately owned property and construction and maintenance will be the sole responsibility of the landowner.

5.3.2 HEIGHT LIMITS

The following standards shall apply to all walls and fences in all residential development. Height limits for all walls, fences and hedges are as follows:

- In a required front yard setback or street-facing side yard setback on corner lots, a fence, a combination of a wall and a fence, or a vegetative hedge shall not exceed a maximum height of four ft. as measured from existing finish grade.
 - For a combination of a wall and a fence, the wall portion shall not exceed a maximum height of 2 ft. The portion above the 2 ft. high wall shall be non-view obscuring with 50 % visibility.
 - Decorative elements, such as pillars, spikes, lights or similar ornamentation may exceed the maximum allowed height for walls and fences.
 - Pedestrian gateways shall have a maximum of 7 ft. height clearance as measured from grade.
 - Any fence in the front yard setback or street-side yard setback areas shall be non-view obscuring with 50 % visibility, except side yard fences within the front yard setback area for an interior lot can be view obscuring.
- In a side or rear yard, no fence or wall shall exceed a height of 6 ft. as measured from the existing finish grade. Coyote rollers can be installed above the permitted 6 ft. high wall or fence in a side or rear yard.
- In a multiple-family zone, a non-view obscuring fence shall not exceed a height of 6 ft. along the street-facing side yard, outside of the front yard setback, for a corner lot.
- For private schools in residential zones, a non-view obscuring tubular steel fence shall not exceed a maximum height of 8 ft.

5. The combined height of the wall retaining a fill and a freestanding fence or wall built above the retained earth level shall not exceed the maximum height allowed for a freestanding fence or wall within the setback area.

5.3.3 APPEARANCE AND INTEGRATION

Walls and fences style shall be integrated with adjacent structures and terrain and utilize landscaping and vegetation materials to soften their appearance.

5.3.3.1 MATERIALS & COLOR

1. Walls and fencing shall be complementary of the architecture in the plot/development area by incorporating building colors and materials, which shall adhere to the design standard outlined in Chapter 4: Architecture Styles.
2. Walls and fencing shall complement and be compatible with the overall landscape materiality palette and design theme, which shall adhere to the design standard in Chapter 5.

5.3.3.2 MATERIAL DURABILITY

1. Wall design and selection of materials shall consider maintenance feasibility, especially graffiti removal and long-term maintenance.

5.3.3.3 VISUAL INTERESTS

1. Perimeter walls shall incorporate at least two (2) different textures, staggered setbacks, and design articulation in conjunction with landscaping to provide visual interest and soften the appearance of the walls.
2. Perimeter walls shall incorporate decorative columns or pilasters covered in stone or brick veneer to provide visual relief. The maximum unbroken length of a perimeter wall shall be 50 ft..

5.3.4 WALL CAPS

Wall caps shall be incorporated as a horizontal design element at the top of walls and shall not exceed 4 inches in vertical thickness. Decorative capstones on stucco walls shall be implemented to prevent water damage from rainfall and moisture.

5.3.5 SCREENING AND NOISE MITIGATION

1. Screen walls, sound walls, and retaining walls shall be used to mitigate noise generators and provide privacy for residents. Screening measures include, but are not limited to, landscaping, alternate window and balcony placements, placing windows at least 6 ft. from the floor of the interior of the unit, incorporating wing walls or louvers, using glass block or other translucent material, and other such methods.
2. Walls required for noise mitigation may exceed maximum height limit, as determined by an acoustical analysis and approved by Director.
3. When a multi-story building is proposed and the second story or above is located within 50 ft. of the side or rear yard of a single-family lot, screening measures shall be applied to provide a minimum of 85% surface area screening, as measured from the finished floor of the private open space to the top of the railing, fencing or walls.

5.3.6 GENERAL

In residential zones, all proposed fence or wall material shall be compatible with the architectural style and treatment of the primary residential structure. All fences and walls shall be made of materials generally used for fencing such as masonry, vegetative hedges, wood, vinyl, brick, ornamental concrete blocks, ornamental tubular steel, or wrought iron, and must have a finished appearance. Acceptable finish treatments include colored stucco, wood stain, natural or polished stone, slump stone, split-faced concrete block, prefabricated finish texture, color-coated tubular steel or wrought iron, or a combination thereof. Plain concrete block masonry shall be permitted only if coated with colored stucco, cement plaster, sealers or coatings, textured or decorative coatings, or color that is integrated during the manufacturing process.

5.4 LANDSCAPE LIGHTING

INTENT

- Enhance the visual and exterior interest of planted areas.
- Provide an appropriate level of illumination along pathways and stairs for residents and guests to increase safety and security along paths of travel.
- To illuminate recreation and communal spaces allowing nighttime use.

5.4.1 TYPES OF LIGHTING

Landscape architects and electrical engineers shall implement a variety of lighting types shown in the table below to illuminate the development’s landscape appropriately.

LANDSCAPE LIGHTING: TYPES

DEFINITION	
SPOTLIGHT	Known as uplights, downlights, directional lights or bullets most commonly used to illuminate trees in the landscape.
PATH & AREA	Path lights illuminate paths and walkways. Area lights increase visibility to the area around the fixture and can be used to light landscape beds.
FLOOD LIGHTS	Flood lights add security and light up property at night. Flood lights commonly have a much higher wattage and wider angle than spotlights.
WALL WASH LIGHTS	This type of flood light is used to provide even illumination across a wide surface.
WELL LIGHTS	Well and in-grade lights are installed below ground (grade) level. The fixture may sit in a turf area or hardscape where foot or vehicular traffic will pass over.
DECK LIGHTS	Deck lights are designed to attach to fence posts and can be mounted on the sides of nearby structures and stairs.
STEP LIGHTS	Step lights illuminate treads and or risers of stairs.
HARDSCAPE LIGHTS	Hardscape lights attach to the underside of capstones and overhangs most commonly floodlight surfaces such as patios, walkways, driveways, stairs, walls and outdoor kitchens or fireplaces.

TABLE 5.3: LANDSCAPE LIGHTING TYPE DEFINITION

5.4.2 LOCATION

1. Accent lighting shall be used to illuminate walkways, parking areas, entries, seating areas, and/or specimen plants and trees.
2. Spotighting or glare from any site lighting shall be shielded from adjacent properties and directed at a specific on-site object or target area.
3. Landscape lighting fixtures shall be incorporated in water features.
4. Path lights, if used, shall be placed min. 12-18 inches away from edge of paving and be incorporated with landscape rock/boulders or similar objects for protection.

5.4.3 LIGHT COLOR

The color of landscape lighting is essential as it provides appropriate warmth to outdoor spaces, enhancing the atmosphere and overall aesthetic of the project. Thoughtful selection of light color creates a welcoming environment that complements the natural landscape and architectural features. The standard of light color is as follows:

LIGHT COLOR

	MIN.	MAX.
COLOR TEMPERATURE (KELVIN)	3000	5000



TABLE 5.4: LIGHT COLOR TEMPERATURE STANDARD

5.4.4 CONCEALMENTS

Light sources for wall washing and tree lighting shall be hidden.

5.4.5 FIXTURE DESIGN

Lighting fixtures shall complement and be compatible with the overall landscape material palette and design theme, as well as the building’s design and architectural style.

5.5 SITE FURNISHINGS

INTENT

- To require site furnishings in all multifamily and mixed-use commercial/residential developments to support the needs of residents and visitors.
- To ensure site furnishings adequately serve the population of guests and residents in the developments mentioned above.
- Proper selection of furnishings will help to integrate the development and further advance the sense of place.

Deep seating site furniture, waste receptacles, drinking fountains, tables, chairs, pottery, planters and umbrellas should compose the majority of site furnishings.

5.5.1 LOCATION

1. Site furnishings shall be strategically placed to offer pedestrians the amenity that would best suit the location, i.e., benches under shade trees, tables, chairs and umbrellas in plazas and waste receptacles in plazas and at intersections.
2. When placed in a recreation-centric setting, in multi-family projects with single family homes and a common open space area provided for the entire community, site furnishings shall be clustered to maximize effective use and minimize the negative visual impact within landscape.
3. The use of benches in the public right-of-way shall be limited; groupings of individual chairs for seating options are preferred.

5.5.2 APPEARANCE & MATERIALS

1. The site furniture shall combine deep seated chairs, coffee tables, trash receptacles, dining tables and chairs. These elements shall be of a consistent 'family' that incorporates the same forms and materials in its design.
2. All site furnishings shall be constructed of durable materials and designed for minimum maintenance, heavy public use and with local climate conditions in mind.
3. Simple designs, instead of ornate decorations, shall be specified for their timeless appeal and ability to be incorporated within each architectural style district.
4. When wood is used as a furnishing material, the wood products must comply with the Forest Stewardship Council's (FSC's) approved list of products and manufacturers, which regulates environmentally responsible forest management.

5.5.3 PLAN SUBMISSION

Applicant shall submit product cut sheets of each typical piece of furniture for City approval.

5.5.4 POTS

1. Applicant shall implement pottery as site amenities, where an at-grade or raised planting area is not appropriate.
2. Pottery shall be used at building entries to direct flow of pedestrian traffic or provide an elevation and height design aesthetic in relationship to the adjacent architecture.
3. Selection of plant material placed in pottery shall be appropriate for growing and irrigation conditions of the pot(s).
4. Pottery design, massing, materiality and color and shall be complementary of development architectural style.